



## **Copyright**

The entire contents of this instruction manual, including any future contents updates, revisions, and specification modifications, shall remain the property of Alltek Marine Electronics Corp. (hereinafter called AMEC) CYPHO-101 Series Automatic Identification System Receiver at all times. Unauthorized copies or reproduces of this manual, either in part or as a whole, is prohibited. The contents herein can only be used for the purpose subjects to this manual.

## **Disclaimer**

The contents of this manual are well prepared by AMEC. While we try to improve our equipments at all times, AMEC shall incur no liability based on the contents, updates or modification of the contents, or the lack of contents in this manual.

## **Contact us at:**

### **Technical Support:**

(Your Local Dealer/Agent Warranty Stamp)
--

### **Sales & Marketing:**

ALLTEK MARINE ELECTRONICS CO., LTD  
7F, NO. 605, Ruei-Guang RD., Neihu, Taipei, Taiwan 114

**TEL: +886 2 2627 1599**

**FAX: +886 2 2627 1600**

**[www.alltekmarine.com](http://www.alltekmarine.com)**



## WARNING!

The equipment said in this manual must only be used to which it was designed. Improper operation or installation may cause damages to the equipment or personal injury. AMEC will not incur any liability of equipment damage or personal injury due to improper use or installation of the equipment. It is strongly recommended to read this manual and the following safety instructions before proceeding to installation or operation.

## SAFETY INSTRUCTIONS

### WARNING



**ELECTRICAL SHOCK HAZARD.**  
Do not open the case of the equipment. Only qualified personnel should work inside the equipment.

**TURN OFF THE POWER IMMEDIATELY IF WATER LEAKS INTO THE EQUIPMENT OR OBJECT DROPS INTO THE EQUIPMENT.**

Continue operating the equipment could cause electrical shock or fire. Contact your nearest distributor for service.

**DO NOT DISASSEMBLE OR MODIFY THE EQUIPMENT.**

Improper disassemble or modification could cause electrical shocks, fire, or personal injury.

**AVOID OPERATING THE EQUIPMENT WITH WET HANDS.**

Electrical shocks could be resulted if operating with wet hands.

**PLEASE USE THE PROPER FUSE.**

Damage to the equipment or fire could be resulted if using the wrong fuse.

### WARNING

**TURN OFF THE POWER IMMEDIATELY IF THE EQUIPMENT IS EMMITTING SMOKE OR FIRE.**

Continue operating the equipment could cause electrical shock or fire. Contact your nearest distributor for service.

**EVEN THOU THE EQUIPMENT IS WATERPROOF, PLEASE AVOID DIRECT CONTACT WITH RAIN FALLING OR WATER SPLASH.**

Electrical shock or fire could be resulted if water leaks into the equipment.

**DO NOT PLACE ANY LIQUID-FILLED CONTAINER ON TOP OF THE EQUIPMENT.**

Improper disassemble or modification could cause electrical shocks, fire, or personal injury.



## **FORWARD**

ALLTEK MARINE ELECTRONICS (hereinafter called "AMEC") thank you for choosing our CYPHO-101 Series Automatic Identification System Receiver (hereinafter called "AIS Rx"). No matter where you sail, and how you should enjoy your voyage journey, we are confident that having our AIS Rx on board would just let you have a better control on your surrounding sea.

The equipment you have purchased is with precision performance and quality. Each of AMEC's equipment has been strictly tested to meet the rigorous demands of the marine environment. Unless improper use or false installation or maintenance, the equipment should be properly functioned at its best.

**We again thank you for choosing our product and we wish you a bon voyage.**



## Table of Contents

---

- I. COPY RIGHT & DISCLAIMER
- II. WARNING & SAFETY INSTRUCTION
- III. FORWARD

	Page
<b>1. PRODUCT DESCRIPTION</b> .....	1
<b>1.1 AIS SYSTEM OVERVIEW</b> .....	1
<b>1.2. AIS COVERAGE</b> .....	2
<b>1.3. AIS VERSUS RADAR</b> .....	2
<b>1.4. TYPE OF AIS</b> .....	3
<b>1.5. AIS DATA INFORMATION</b> .....	4
<b>1.6. AIS REPORT RATE</b> .....	5
<b>1.7. AMEC AIS RECEIVER FEATURES</b> .....	6
<b>1.8. IMPORTANT NOTICE</b> .....	7
<b>2. INSTALLATION GUIDE</b> .....	8
<b>2.1. GENERAL</b> .....	8
<b>2.2. INSTALLATION PROCEDURE</b> .....	15
<b>2.3. CABLING</b> .....	30
<b>2.4. AMEC CYPHO-101(G) EXTERNAL CONFIGURATION</b> .....	31
<b>3. SOFTWARE INSTALATION</b> .....	33
<b>3.1 INSTALL THE USB DRIVER</b> .....	33
<b>3.2 CONFIGURATION (CYPHO-101 &amp; CYPHO-101G only)</b> .....	35
<b>3.3. INSTALL THE AIS VIEWER ON PC</b> .....	37
<b>4. GET STARTED</b> .....	40
<b>4.1. FAMILIARIZE YOURSELF WITH THE FRONT PANEL AND ALL THE INDICATION LIGHTS</b> .....	40
<b>4.2. TURNING POWER ON / OFF</b> .....	40
<b>5. AIS VIEWER APPLICATION GUIDE</b> .....	42
<b>5.1. Serial Port Setting</b> .....	42
<b>5.2. AMEC AIS VIEWER QUICK START</b> .....	43
<b>5.3. AMEC AIS VIEWER RADAR VIEW</b> .....	44
<b>5.4. Quick Start</b> .....	46
<b>5.5. MAIN DISPLAY</b> .....	47
<b>6. TROUBLE SHOOTING</b> .....	61



<b>6.1. PROBLEM ANALYSIS (BY STATUS INDICATION LIGHT)</b> .....	61
<b>6.2. PROBLEM ANALYSIS (HARDWARE)</b> .....	62
<b>7. SPECIFICATIONS</b> .....	63
<b>8. AMEC World Wide Warranty</b> .....	65
<b>9. Federal Communication Commission Interference Statement</b> .....	68
<b>10. INDUSTRY CANADA NOTICE</b> .....	68
<b>11. Declaration of Conformity</b> .....	68
<b>12. ABBREVIATIONS</b> .....	69

# 1. PRODUCT DESCRIPTION

## 1.1 AIS SYSTEM OVERVIEW

AIS is one of the latest AtoN equipments allowing real-time information exchanged between vessels and Vessel Traffic Service system.

AIS uses marine VHF channel with frequency set universally from 156.025 MHz to 162.025 MHz. AIS applies the broadcast method of time division multiple access (hereinafter called "TDMA") to transmit in a 2,250 messages per minute rate. The whole broadcasting process does not require manual operating and it automatically generates networks so vessels can be easily identified with each other.

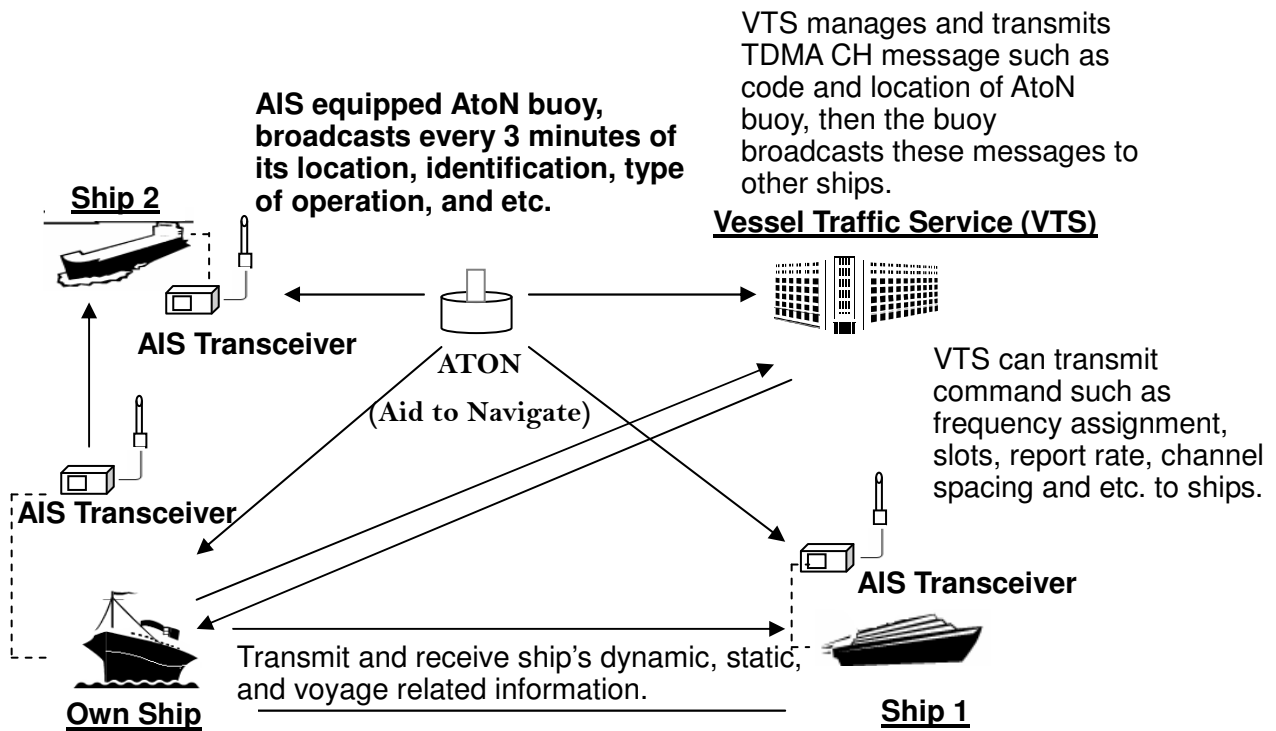

Picture 1-1 System overview

AIS system is also capable of integrating and combining with other maritime system such as Electronic Chart System (hereinafter called "ECS"). AIS' wide applications and its exceptional AtoN value greatly enhance other maritime systems' performance.

Having an AIS system on board not only can monitor the status of the vessels in the surrounding sea, but also receive the dynamic information (position, speed, SOG, and etc), static information, and voyage related information from any vessels equipped with an AIS systems.



## **1.2. AIS COVERAGE**

The system radio coverage is similar to other VHF radio applied products; however, the transmission of AIS system depends upon the length of the external antenna and the earth's curvature. The longer the antenna and its placement and height settings will vary slightly in the signal's transmission. Generally, the AIS signal coverage will be around 25 nautical miles.

## **1.3. AIS VERSUS RADAR**

Each AIS equipped vessel automatically broadcasts its own vessel information and will not encounter signal blocked out by capes or islands. AIS also constantly updates and broadcasts its speed, voyage related information and all other pertinent information. In comparison to radar systems, AIS is far more effective in showing a vessel's real-time voyage status and providing collision avoidance warnings in ample time.

AIS is primarily designed for the purpose of collision avoidance. It greatly enhances the add-on value of other maritime systems such as the ARPA Radar, VTS and others. An AIS-integrated ECS system can easily plot all vessel information, such as vessel names, positions, headings and other information on its plotter.



### 1.4. TYPE OF AIS

Your AMEC CYPHO-101 Series AIS Receiver automatically receives the following information from other vessels, shore based stations and AtoN such as buoy and etc.

**Table 1-1 Type of AIS**

<b>Class A AIS</b>	<ul style="list-style-type: none"><li>• Transmits and receives AIS signal.</li><li>• Intended for vessels to meet the requirements of IMO AIS carriage requirement.</li><li>• The Class A AIS is mandated to be installed on all commercial vessels exceeding 300 tons.</li></ul>
<b>Class B AIS</b>	<ul style="list-style-type: none"><li>• Transmits and receives AIS signal.</li><li>• Not necessarily in full accordance with IMO AIS carriage requirements.</li><li>• The Class B AIS currently is not mandated to be installed on any vessels.</li><li>• Suitable for recreational purpose enhancing the safety at sea.</li></ul>
<b>AIS Receiver</b>	<ul style="list-style-type: none"><li>• Receives AIS signals only.</li><li>• Does not have transmitter to send out AIS signals.</li><li>• Economic smart for recreational vessels.</li></ul>



## 1.5. AIS DATA INFORMATION

Your AMEC CYPHO-101 Series Class B AIS automatically exchanges the following information with other vessels and shore-based stations. The information is also exchanged between your AIS and the AtoN, i.e.: buoys.

In the following table, some data details are highlighted in black and these data are mandated, by law, to be transmitted and received from Class B AIS equipped vessels only.

**Table 1-2 AIS data information**

Type of Data	Data Details
<b>Static Data</b>	Maritime Mobile Service Identity (hereinafter called “MMSI”) number. IMO number. Call sign and name. Type of ship. Length and beam. GPS Antenna location.
<b>Voyage Related Data</b>	Draught of the ship. Cargo information Destination Estimate Time of Arrival (hereinafter called “ETA”)
<b>Dynamic Data</b>	Position of the vessel. Coordinated Universal Time (hereinafter called “Time in UTC”.) Course Over Ground (hereinafter called “COG”). Speed Over Ground (hereinafter called “SOG”). Heading Rate of turn Navigational status
<b>Dynamic Reports</b>	Speed of the ship Status of the ship
<b>SRM</b>	Alarm Safety



## 1.6. AIS REPORT RATE

### Class A AIS

SOTDMA Broadcasting Method:

**Table 1-3-1 AIS report rate**

<b>Ship's Dynamic Conditions</b>	<b>Nominal reporting interval</b>
Ship at anchor or moored and not moving faster than 3 knots	3 Minutes
Ship at anchor or moored and moving faster than 3 knots	10 Seconds
Ship 0-14 knots	10 Seconds
Ship 0-14 knots and changing course	3 1/3 Seconds
Ship 14-23 knots	6 Seconds
Ship 14-23 knots and changing course	2 Seconds
Ship >23 knots	2 Seconds
Ship >23 knots and changing course	2 Seconds

### Class B AIS

There are two different data report rates of the AIS class B. One report rate is in accordance with ITU-RM. 1371 standard with SOTDMA broadcasting method. The other is in accordance with IEC-62287 standard with CSTDMA broadcasting method. For details please refer to the following tables.

SOTDMA Broadcasting Method:

**Table 1-3-2 AIS report rate**

<b>Ship's Dynamic Condition</b>	<b>Nominal Reporting Interval</b>
Class B Ship-borne mobile equipment not moving faster than 2 knots	3 Minutes
Class B Ship-borne mobile equipment moving 2-14 knots	30 Seconds
Class B Ship-borne mobile equipment moving 14-23 knots	15 Seconds
Class B Ship-borne mobile equipment moving faster than 23 knots	5 Seconds
Search and Rescue aircraft (airborne mobile equipment)	10 Seconds
Aids to Navigation	3 Minutes
AIS base station	10 Seconds



CSTDMA Broadcasting Method as follows:

**Table 1-3-3 AIS report rate**

<b>Ship's Dynamic Condition</b>	<b>Nominal Reporting Interval</b>
Class B Ship-borne mobile equipment not moving faster than 2 knots	3 Minutes
Class B Ship-borne mobile equipment moving faster than 2 knots	30 Seconds
Report rate by command of VTS	5 Seconds highest

## **1.7. AMEC AIS RECEIVER FEATURES**

- Receives & monitors data of Class A & Class B AIS broadcast.
- Viewer program includes 2 viewing modes: Radar view and Alphanumeric view.
- Advanced collision avoidance system effectively enhanced the situational awareness.
- Fully corresponds to the IMO issued technical specification.
- Dual Channel Receiver Design.
- NMEA 0183 interface providing high compatibility with major AIS-ready navigation systems.
- PC / Laptop connecting enabled.
- Optional:
  - GPS enabled



## 1.8. IMPORTANT NOTICE

The intended use of the AMEC CYPHO-101 Series Automatic Identification System Receiver is to enhance the safety of vessels at sea. However, a few points must be noticed as below:

- Under certain regulations, some specified vessels are compulsory to be installed with AIS. However, this does **NOT** mean that all vessels will be equipped with ones. Any AIS will **NOT** guarantee to monitor and to receive signals from every ship in the surroundings.
- AIS acts as aids to navigation in the purpose of decreasing or preventing the possibility of vessel collision. It is not navigational equipment and does not replace any navigational system installed on board.
- Although an AIS Receiver is operated automatically by itself, the owner or the crew on the vessel is suggested to maintain a proper look-out for the surroundings. While the AIS is capable of setting alarm of Distance to Closest Point of Approach (hereinafter called “CPA”) and Time to the Closest Point of Approach (hereinafter called “TCPA”), vessel owner or the crew should be aware of the fact that such action will not apply on the vessels that are not equipped with AIS.
- Any incorrect data and information entered into the AIS system is considered as erroneous information. Potential unknown risks may result to other vessels and the own vessel when erroneous information or improper messages being transmitted. Users must be aware of this and make sure that all the information entered into the system is correct and up to date.
- Please keep the device at least 3.3ft (1 m) away from the ship’s navigation compass.
- This product is a marine AIS receiver intended for worldwide use abroad NON SOLAS vessels.

## 2. INSTALLATION GUIDE

### 2.1. GENERAL

#### 2.1.1. SAFETY INSTRUCTION

Before proceeding with installation, please take notice of the following safety instructions and carefully read thru this installation manual.

### SAFETY INSTRUCTIONS

<b>WARNING</b>
 <p><b>ELECTRICAL SHOCK HAZARD</b> Do not open the case of the equipment. Only qualified personnel should work inside the equipment.</p>
<p><b>TURN OFF THE POWER BEFORE PROCEEDING WITH INSTALLATION.</b> Proceeding with installation with the power on could cause electrical shock or fire.</p>
<p><b>AVOID INSTALLING THE EQUIPMENT WHERE THERE IS DIRECT CONTACT WITH RAIN FALLING OR WATER SPLASH.</b> Electrical shock or fire could be resulted if water leaks into the equipment.</p>
<p><b>MAKE SURE THE POWER SOURCE AND THE POWER INPUT OF THE EQUIPMENT ARE COMPATIBLE.</b> Damage to the equipment and fire could be resulted if the power sources are not correct. Please check the correct power input on the adaptor.</p>

**PLEASE FOLLOW THIS INSTRUCTION MANUL TO PROCEED WITH THE INSTALLATION.**  
AMEC and your local agent/dealer will not bare any responsibility of equipment damage or personnel injury due to improper installation.

 **WARNING**

**Warning Label**  
A warning label (picture 2-1) is attached underneath the equipment. Warranty of the equipment will be invalid if this label is detached or broken. AMEC and your local agent/dealer will not bare any responsibility of any damage to the equipment, or damage in related to the equipment, personnel injury, and etc. if this label is detached or broken. Please contact your local agent/dealer if this label is missing.

<p><b>Warning</b></p>  <p>注意</p>	<p>Name: Warning Label No Warranty if this label is detached or broken. 保固撕毀无效</p>
---	--

Picture 2-1 Warning label



### 2.1.2. ABOUT THIS MANUAL

This installation manual is written specifically for AMEC CYPHO-101Series AIS Receiver. The installation instructions contained in this manual may only be applied to AMEC CYPHO-101 Series AIS Receiver. While most of the installation can be performed by the owner or the crew, a final commissioning can be done by your local agent/dealer if desired or required. AMEC and the local agent/dealer will not bear any responsibilities of damages resulted from improper installation by unauthorized agent/dealer.

### 2.1.3. CONTENTS OF THIS MANUAL

This installation manual outlines in-depth information, including:

- Components list of the equipment,
- Step-by-step installation instructions,
- Cabling and antenna installation guide,
- Data port interfaces application and external configuration guide,
- AIS application guide and AIS viewer installation guide,
- User interface operation guide.

### 2.1.4. UNPACKING AND HANDLING THE UNIT

<p>① <b>Move and handle with caution. Do not drop or bump.</b></p>	<p>② <b>Visually inspect the box to ensure it's intact.</b></p>	<p>③ <b>Unpack the product on a flat and level surface.</b></p>
<p>④ <b>Unpack the box with the “this side up” sign facing up.</b></p>	<p>⑤ <b>Take extra caution if sharp objects are required to unpacking.</b></p>	<p>⑥ <b>After unpacking, ensure all accessories are included</b></p>



### 2.1.5. ITEMS IN THE PACKAGE

The accessories included in the standard package are shown in Picture 2-2. Contact with your supplier if there is any shortage.

#### 1. CYPHO-101E Package items

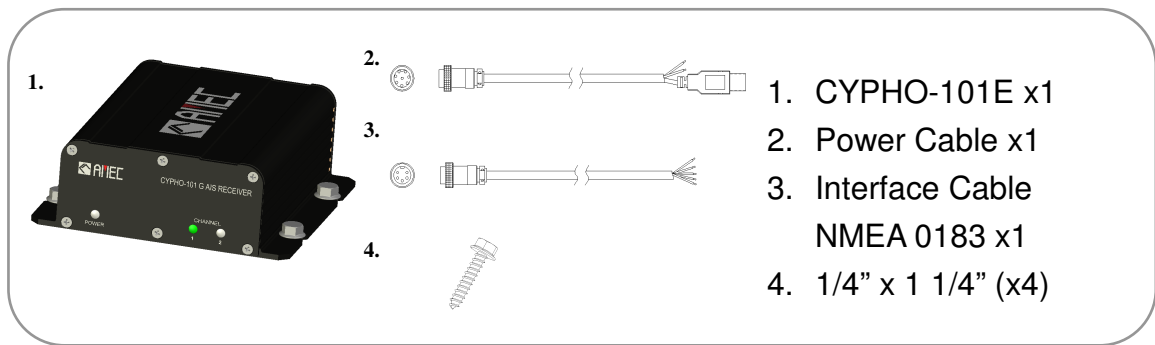

Picture 2-2 CYPHO-101E Package items

### Standard Supply

Table 2-1-1 CYPHO-101E Equipment list

No.	Name	Type	Code No.	Qty	Remarks
1	AIS Receiver	CYPHO-101E	--	1	--
2	Manual	--	M-ACC-USM-AIS-RX05-EN-001	1	--
3	Installation Kit	--	M-ACC-CAB-338-002-0001	1	Power Cable
		--	M-ACC-CAB-338-002-0003	1	Interface Cable 1.5m(NMEA0183)
		--	M-ASM-SCR-SUS TAP1/4" x 1 1/4"	4	1/4" x 1 1/4" Screws



2. CYPHO-101 Package items(Baud Rate Configurable)

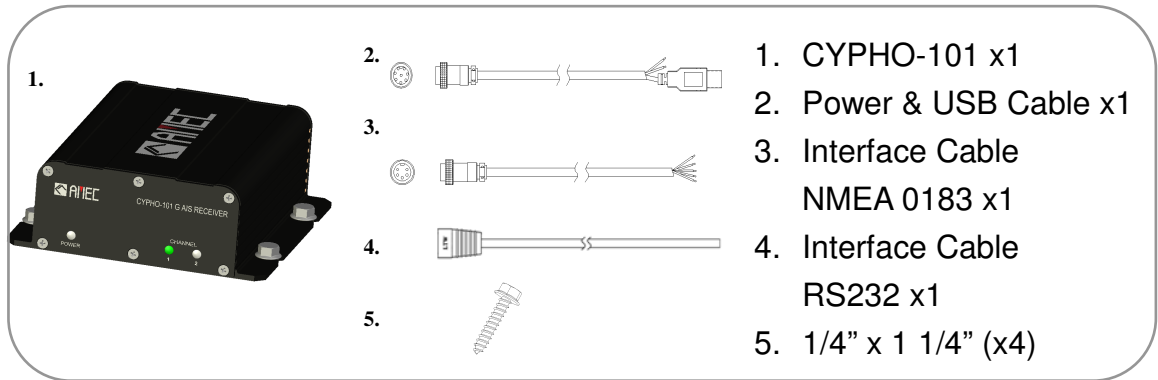

Picture 2-3 CYPHO-101 Package items

**Standard Supply**

Table 2-1-2 CYPHO-101 Equipment list

No.	Name	Type	Code No.	Qty	Remarks
1	AIS Receiver	CYPHO-101	--	1	--
2	Manual	--	M-ACC-USM-AIS-RX05-EN-001	1	--
3	Installation Kit	--	M-ACC-CAB-HJ-338-080506-04	1	Power & USB Cable 1.5m
		--	M-ACC-CAB-338-002-0003	1	Interface Cable 1.5m(NMEA0183)
		--	M-ACC-CAB-HJ-310-003	1	Interface Cable 1.2m(RS232)
		--	M-ASM-SCR-SUS TAP1/4" x 1 1/4"	4	1/4" x 1 1/4" Screws
		--	--	1	Installer software, driver CD & AIS viewer



### 3. CYPHO-101G Package items(Baud Rate Configurable)

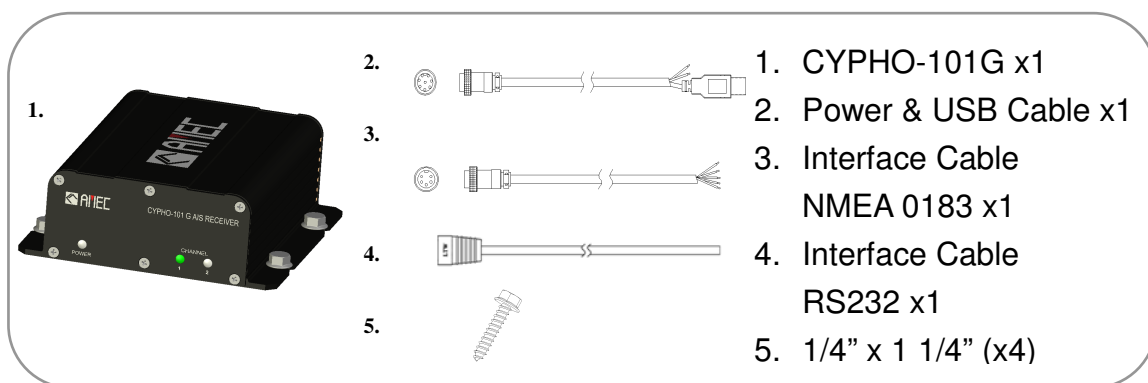

Picture 2-4 CYPHO-101G Package items

### Standard Supply

Table 2-1-3 CYPHO-101G Equipment list

No.	Name	Type	Code No.	Qty	Remarks
1	AIS Receiver	CYPHO-101G	--	1	--
2	Manual	--	M-ACC-USM-AIS-RX05-EN-001	1	--
3	Installation Kit	--	M-ACC-CAB-HJ-338-080506-04	1	Power & USB Cable 1.5m
		--	M-ACC-CAB-338-002-0003	1	Interface Cable 1.5m(NMEA0183)
		--	M-ACC-CAB-HJ-310-003	1	Interface Cable 1.2m(RS-232)
		--	M-ASM-SCR-SUS TAP1/4" x 1 1/4"	4	1/4" x 1 1/4" Screws
		--	--	1	Installer software, driver CD & AIS viewer

### 2.1.6. Optional Supply

Table 2-1-4 Equipment list

No	Name	Model No.	Code No.	Remarks
1	VHF Antenna	--	ALT06-310510	-
2	GPS Antenna	--	C1283-570001	10m cable included
3	VHF Antenna Cable	--	M-ACC-CAB-AT10	10m cable, not included



### 2.1.7. TOOLS REQUIRED

1. Electric Drill
2. 1/4" (4mm) Drill
3. Screw Driver

### 2.1.8. MECHANICAL DRAWING

#### Front View

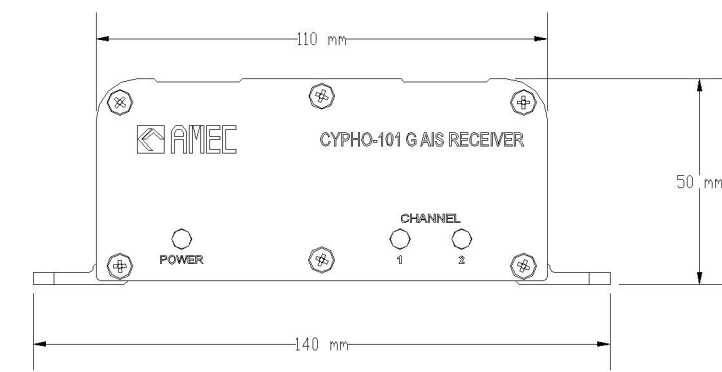

Picture2-5 CYPHO-101(G) front view

#### Top View

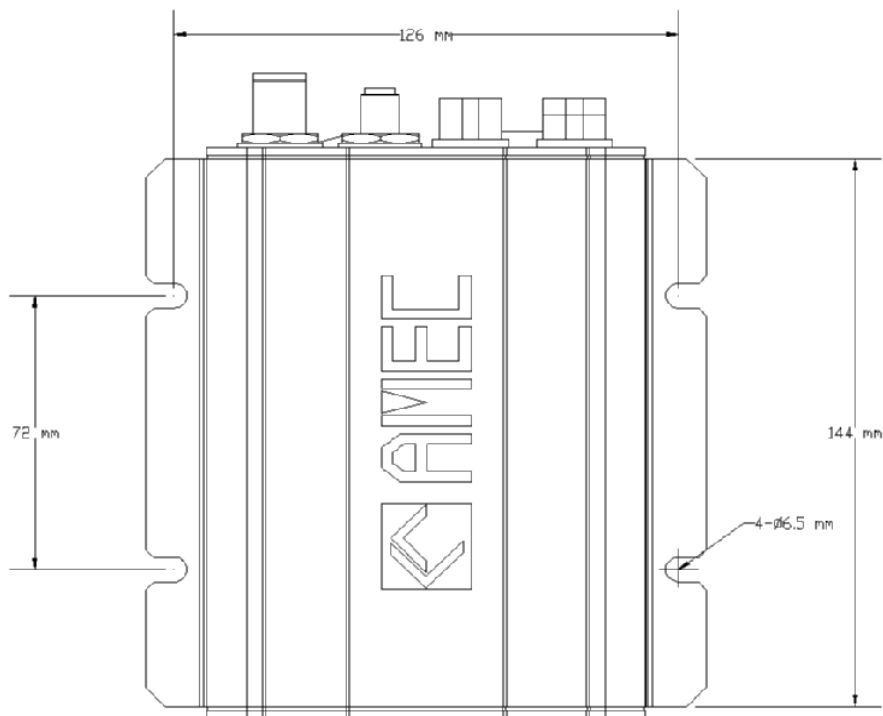

Picture 2-6 CYPHO-101(G) top view

**Side View**

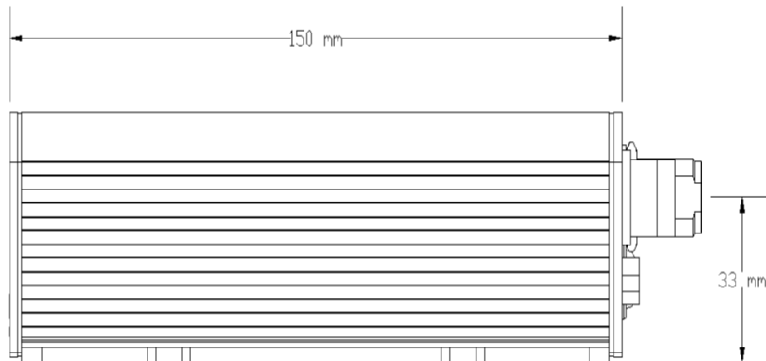

**Picture 2-7 CYPHO-101(G) side view**

**Back View**

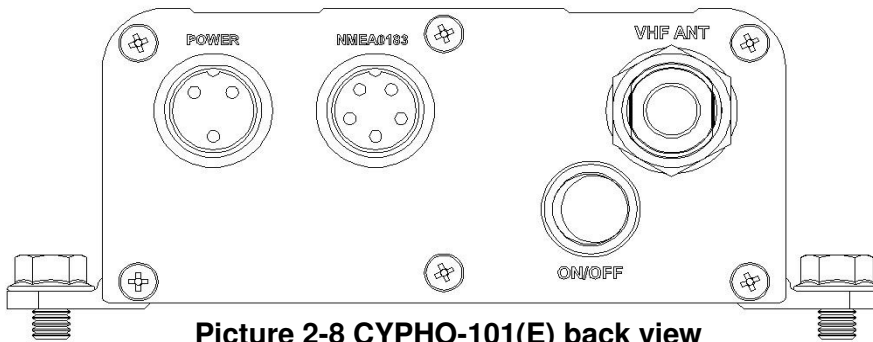

**Picture 2-8 CYPHO-101(E) back view**

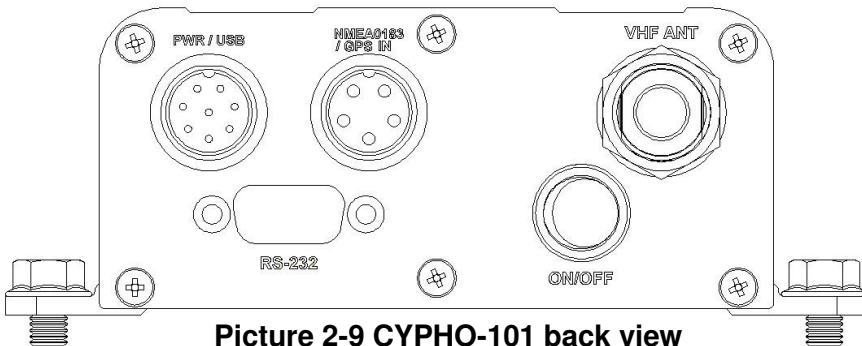

**Picture 2-9 CYPHO-101 back view**

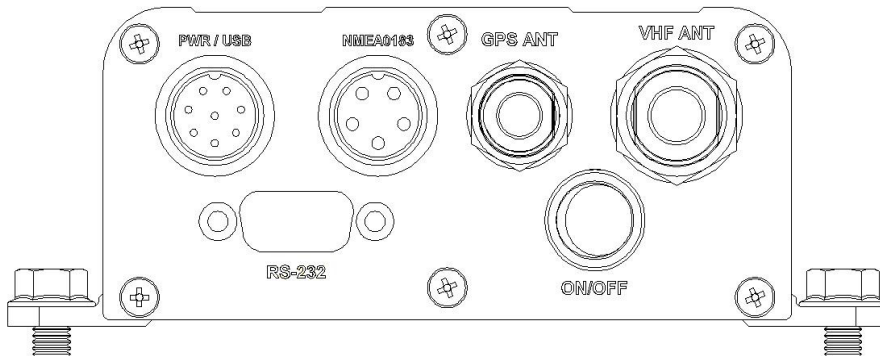

**Picture 2-10 CYPHO-101(G) back view**



## 2.2. INSTALLATION PROCEDURE

### 2.2.1. INSTALLATION PRECAUTIONS

- 1 Install in a safe environment that will in no way come into contact with rain or water splash.
- 2 If a ladder is required for installation, use extra caution and avoid falls.
- 3 Do not place or install the equipment beneath or near any water or liquid filled container.
- 4 Do not place or install the equipment where damage can occur due to tripping, stepping on or kicked.
- 5 Do not place or install the equipment near any generator or engine.

### 2.2.2. STEP BY STEP INSTALLTION INSTRUCTIONS

AMEC CYPHO-101Series can be installed and mounted on flat surface or may be attached on a wall as shown below:

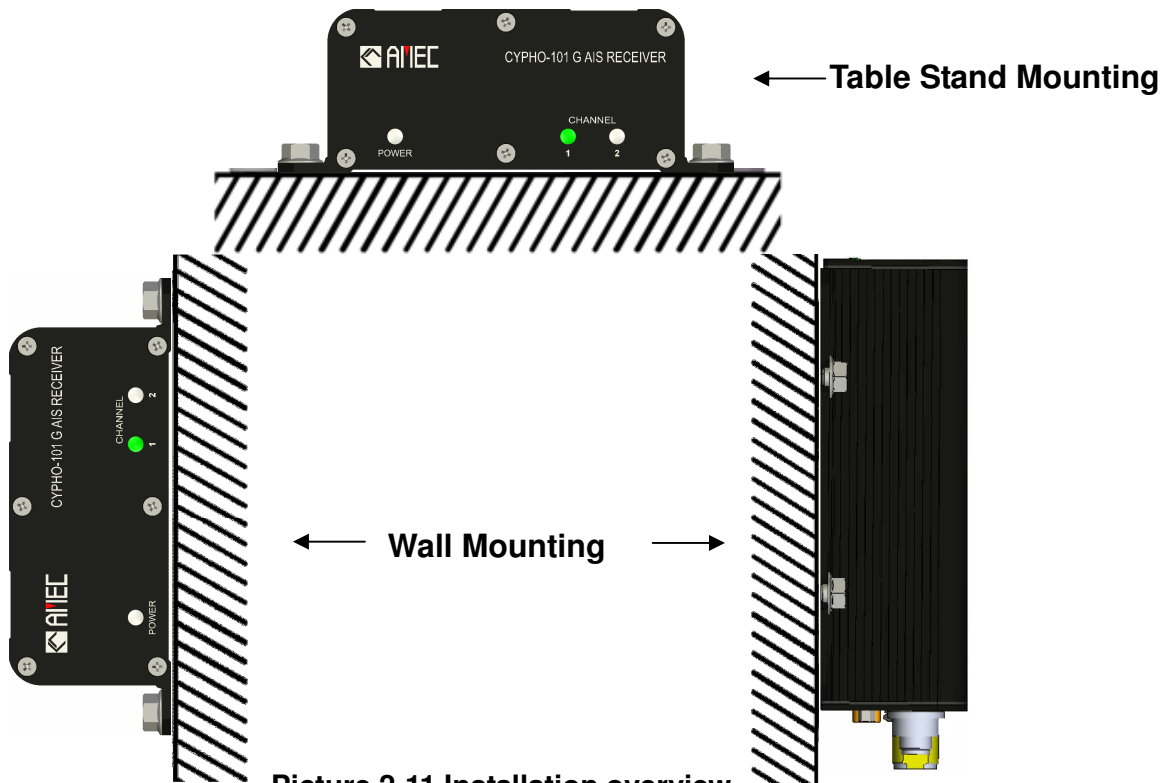



## I. Installation Instructions



### **Step 1:**

Place the Receiver on the desired spot for installing. (Refer to picture 2-12)

### **Step 2:**

Use the 4 1/4" x 1 1/4" screws in the accessories box to screw into the hole. (Refer to picture 2-12)

Picture 2-12 Installation instruction

### 2.2.3. CYPHO-101/101G Cabling Instructions

\* Here picture below is the cabling example of CYPHO-101G whereas CYPHO-101 has no GPS antenna connector included.

#### II. Cabling Instructions

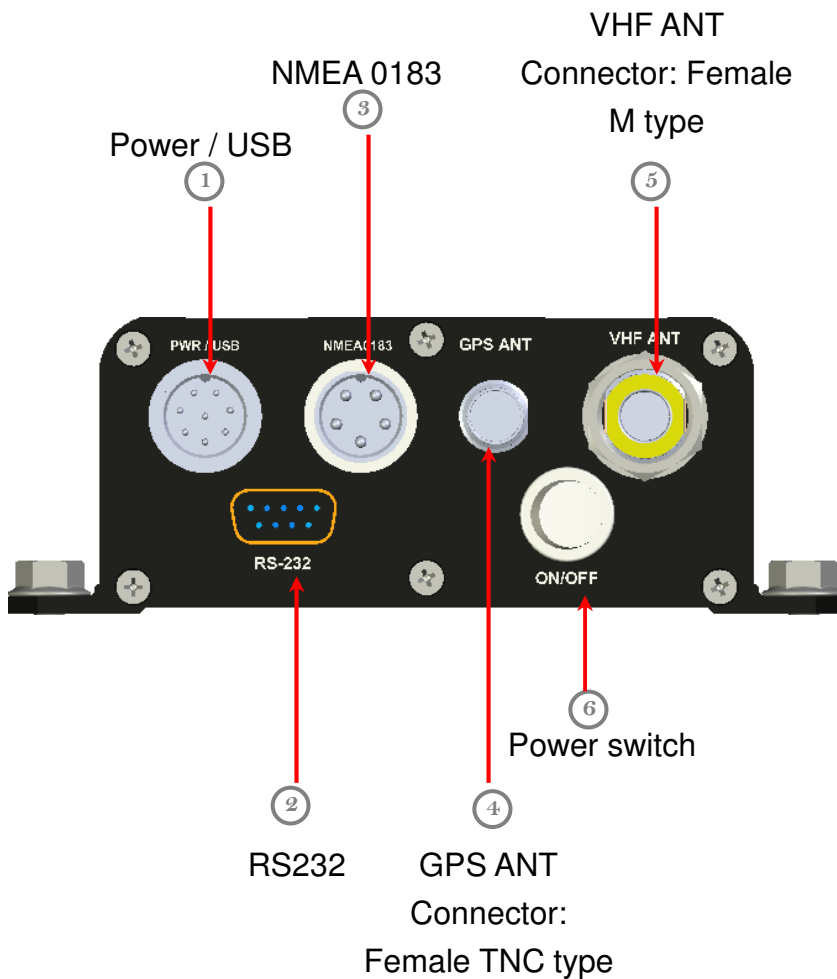

Picture 2-13 Cabling instruction

#### Step 1:

Connect the GPS cable to the GPS ANT (4).

#### Step 2:

Connect the VHF cable to the VHF ANT (5).

#### Step 3:

Connect NMEA 0183 compatible system to the NMEA interface (3).

#### Step 4:

Connect either RS232 (2) or USB attached on the power cable to your computer

**\* Do not connect the two interfaces simultaneously.**

#### Step 5:

Connect the Power cable to the PWR / USB interface (1).

#### Step 6:

Switch the power (6) to "ON" and AMEC CYPHO-101(G) starts to work.

\* GPS together with AIS data can be outputted to your computer either through USB or

“**PWR / USB**”: An USB connector is attached on the power cable. Please refer to the following table 2-2-1 for the wiring details. Please install the USB driver if you would like to connect computer through USB connection (Please refer to Section 3.1). The USB interface may provide power source; nevertheless, a power cable charged is suggested in the normal situation.

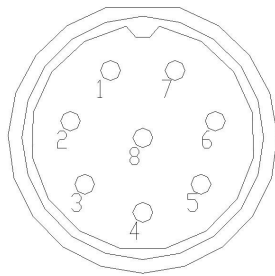

**Table 2-2-1 CYPHO-101/101G PWR/USB wiring**

Pin	Wire Color	Name	Function
1	Red	USB PWR	USB power input, the input should be 5V DC
2	White	D-	USB Data Negative (–)
3	Green	D+	USB Data Positive (+)
4	Black	GND	USB Power Ground
5	Black	FG	USB Frame Ground
6	White	FG	Frame Ground
7	Black	GND	Power Ground
8	Red	PWR	Positive pole, the input should be 9~30V DC

“**NMEA0183**”: The NMEA0183 interface is RS-422 type; the cable contains 5 different wires. Please refer to the following table for the wiring details.

■ **CYPHO-101G (With GPS):**

**Table 2-2-2 NMEA0183 wiring details – with internal GPS module**

Pin	Wire color	Name	Function
1	Blue	TXP	Positive (+); Transmit AIS and GPS information
2	Red	TXN	Negative (-); Transmit AIS and GPS information
3	White	/	/
4	Yellow	/	/
5	Black	FG	Frame Ground

**NMEA0183 Wiring:**

Please refer to the wiring method of external NMEA device to be connected before making connection.

1. Please refer to the following wiring method if the external NMEA device uses NMEA0183 interface (e.g. RS422).

**AMEC AIS NMEA0183**

**External NMEA device**

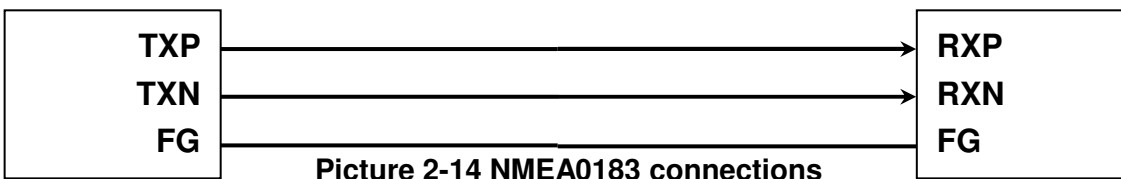

2. Please refer to the following wiring method if the external device is none-fully NMEA0183 complied (e.g. RS232).

**AMEC AIS NMEA0183**

**External NMEA device**

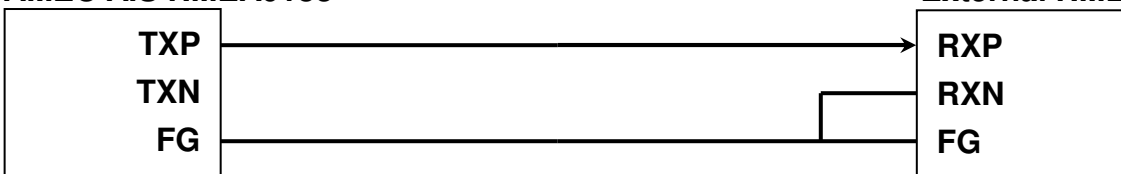



**CYPHO-101 (w/o built-in GPS):**

**Table 2-2-3 NMEA0183 wiring details – no internal GPS module**

Pin	Wire color	Name	Function
1	Blue	TXP	Positive (+); Transmit AIS and GPS Data (The GPS data can be transmitted only if the external GPS signal is presented)
2	Red	TXN	Negative (-); Transmit AIS and GPS information (The GPS data can be transmitted only if the external GPS signal is presented)
3	White	RXP	External GPS signal can be inputted by the line signals.
4	Yellow	RXN	External GPS signal can be inputted by the line signals.
5	Black	FG	Frame Ground

**NMEA0183 Wiring:**

Please refer to the wiring method of external NMEA device to be connected before making connection.

1. Please refer to the following wiring method if the external NMEA device uses NMEA0183 interface (e.g. RS422).

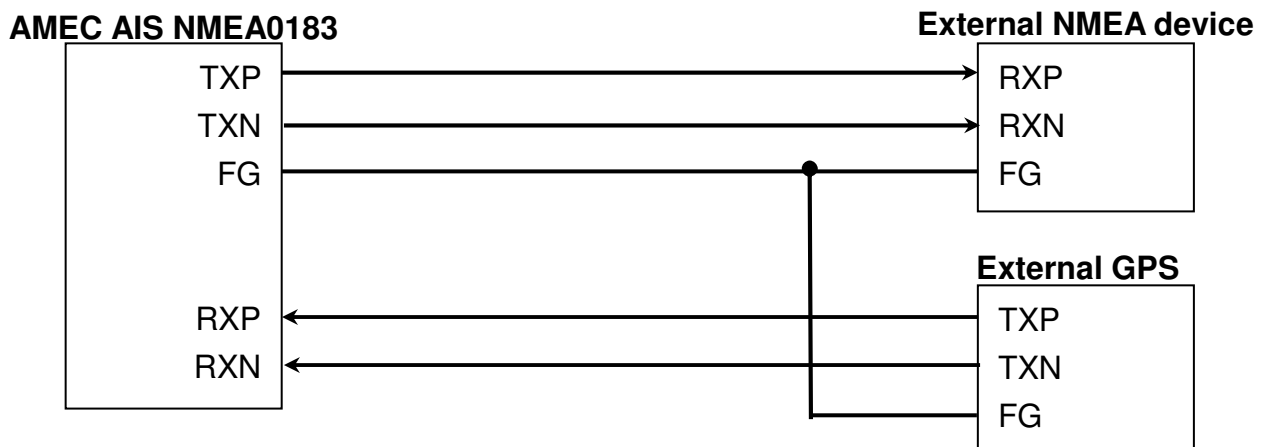

**Picture 2-16 CYPHO-101 NMEA0183 connections**

2. Please refer to the following wiring method if the external device is none-fully NMEA0183 complied (e.g. RS232).

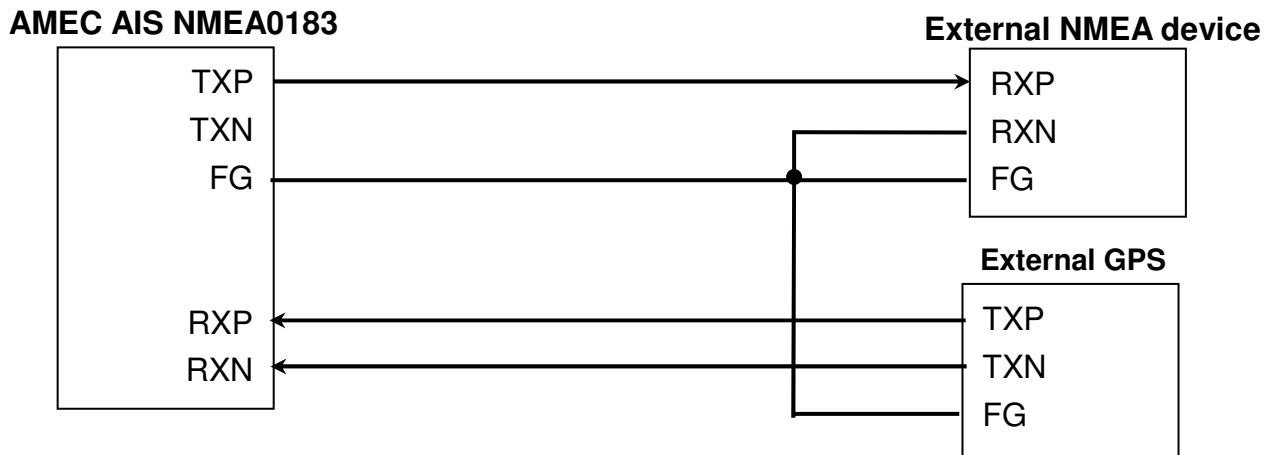

Picture 2-17 connecting to none-fully 0183 device

“RS232”: The cable contains 9 different wires. Please refer to the following table for the wiring details.

Table 2-2-4 RS232 wiring details

NO.	Name	Function
1	/	/
2	/	/
3	TX	Transmit Data
4	/	/
5	GND	Power Ground
6	/	/
7	/	/
8	/	/
9	/	/

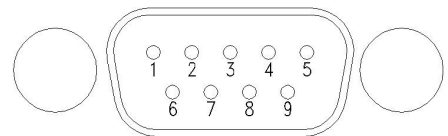

## 2.2.4. CYPHO-101E Cabling Instructions

### II. Cabling Instructions

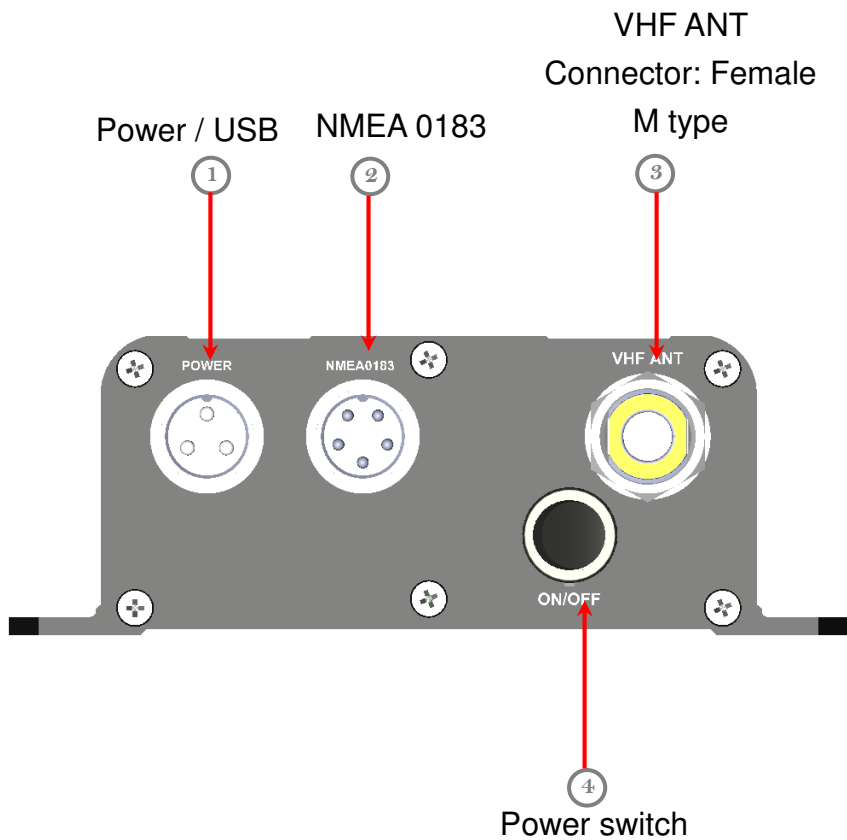

#### **Step 1:**

Connect the VHF cable to the VHF ANT (3).

#### **Step 2:**

Connect NMEA 0183 compatible system to the NMEA interface (2).

#### **Step 3:**

Connect the Power cable to the PWR / USB interface (1).

#### **Step 4:**

Switch the power (4) to "ON" and AMEC CYPHO-101E starts to work.

Picture 2-18 Cabling instruction



“**Power Cable**”: This is the power cable of AMEC CYPHO-101E.

Please refer to the following table for the wiring details.

**Table 2-2-5 CYPHO-101E PWR wiring details**

Pin	Wire Color	name	function
1	White	FG	Frame Ground
2	Black	GND	Power Ground
3	red	PWR	Positive pole, the input should be 9~30V DC

“**NMEA0183**”: The NMEA0183 interface is RS422 type; the cable contains 5 different wires.

Please refer to the following table for the wiring details.

**Table 2-2-6 CYPHO-101E NMEA0183 wiring details**

Pin	Wire color	Name	Function
1	Blue	TXP	Positive (+); Transmit AIS and GPS information
2	Red	TXN	Negative (-); Transmit AIS and GPS information
3	White	/	/
4	Yellow	/	/
5	Black	FG	Frame Ground

**NMEA0183 Wiring:**

Please refer to the wiring method of external NMEA device to be connected before making connection.

1. Please refer to the following wiring method if the external NMEA device uses NMEA0183 interface (e.g. RS422).

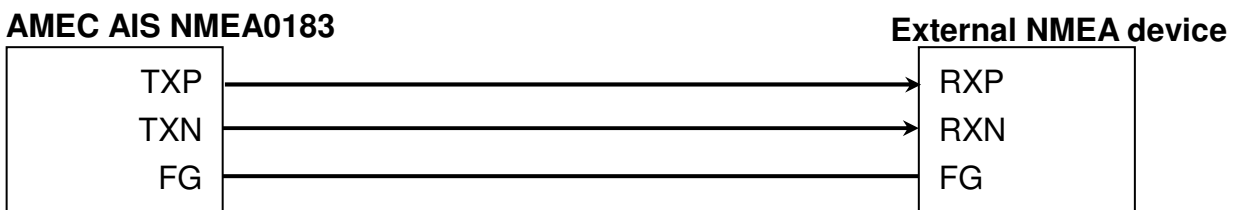

**Picture 2-19 CYPHO-101E NMEA0183 connections**



2. Please refer to the following wiring method if the external device is none-fully NMEA0183 complied (**e.g. RS232**).

Please confirm RXN and FG has being connected if the external desired NMEA devices required to be connected, and then please make the connection with CYPHO-101E ground.

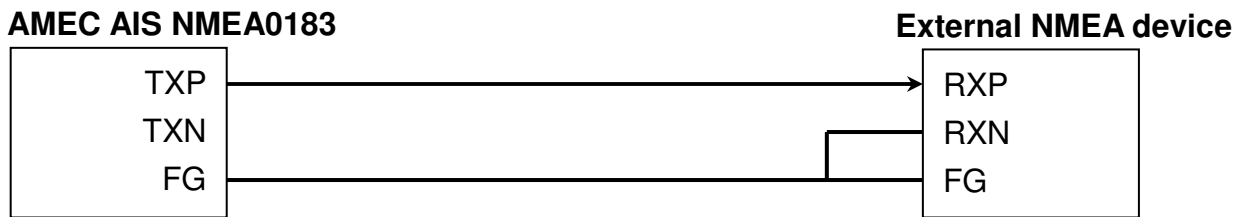

**Picture 2-20 CYPHO-101E connecting to none-fully 0183 device**

## 2.2.5. CYPHO-101G Start-Up Setting

### III. Start-Up Setting



#### **Step 1:**

Connect the power cable with the power input and turn on the CYPHO-101(G) by switching ① to “ON”.

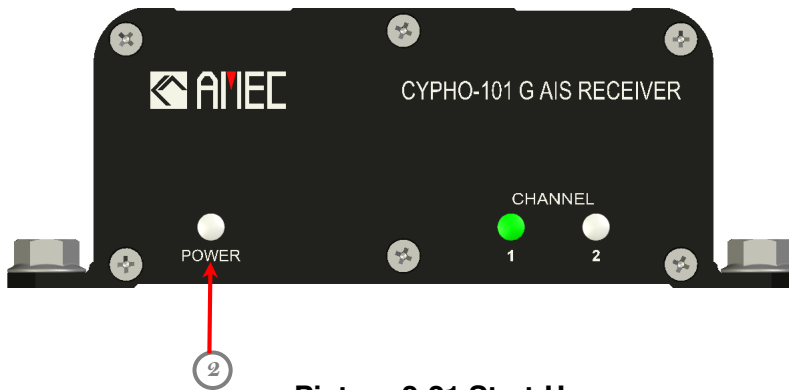

#### **Step 2:**

Ensure the status indication light ② is working properly. Please refer to Section 4.2

Picture 2-21 Start-Up

### IV. REMARKS

①

Set up the GPS and VHF Antenna in an appropriate spot. (Refer to section 2.4.1)

②

The power voltage of CYPHO-101(G) is 9-30V DC.  
**An adaptor is needed if the supply voltage is 110V AC or others.**



**INCORRECT INPUT VOLTAGE WILL RESULT IN SYSTEM DANGER!**

## 2.2.6. OPTIONAL OMNI-DIRECTIONAL ANTENNA SPECIFICATION

### <Specification>



**Table 2-2-7 Specification**

VHF ANTENNA	
<b>Fr :</b>	156 MHz ~ 162 MHz
<b>Gain:</b>	3dB
<b>Configuration :</b>	1/2 wave
<b>VSWR</b>	1.5:1
<b>Impedance:</b>	50 Ω
<b>Connector:</b>	M jack
<b>Ground</b>	without
<b>Length:</b>	1590 mm
<b>Weight:</b>	860 g w/o mount

## 2.2.7. OPTIONAL GPS ANTENNA SPECIFICATION

### <Specification>

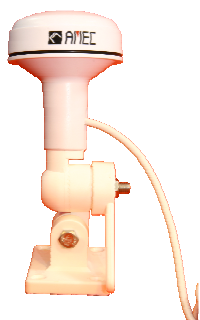
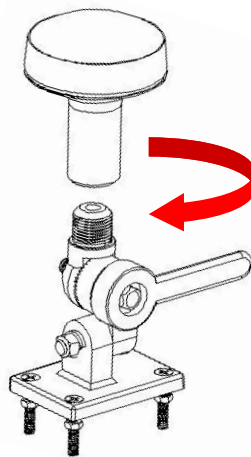

Table 2-2-8 Specification

GPS Antenna	
Outline Dimension	25×25×4mm <sup>3</sup>
Ground Size	Diameter: 74mm
Center Frequency	1575.42 MHz ± 2 MHz
Bandwidth	10 MHz
VSWR	1.5 Max
Axial Ratio @ Zenith	3 db Typical
Gain @ Zenith	5 dBi Typical
Gain @ 10° Elevation	-1 dBi Typical
Radiation Efficiency	84.42%
Output Impedance	50Ω
Polarization	RHCP
LNA	
Frequency	1575.42 MHz
Gain	28 dB Typical
VSWR	1.92 Max
Noise Figure	1.5 dB Typical
Out-Band Attenuation	20 dB min. @ 50MHz
DC Power Input	3 ~ 5 V
Power Consumption	4.8 mA @ 2.7 V
	6 mA @ 3.3 V
	10.43 mA @ 5 V
Output Impedance	50Ω

Table 2-2-9 Specification

<b>Overall Performance (GPS Antenna, LNA and Coaxial Cable)</b>	
Frequency	1575.42 MHz
Gain	30 dB Typical
Noise Figure	1.5 dB Typical
Axial Ratio @ Zenith	3 dB Typical
VSWR	1.5 Max
Output Impedance	50Ω
<b>Environmental Conditions</b>	
Operating Temperature	-30°C ~ 80°C
Storage Temperature	-40°C ~ 100°C
Relative Humidity	45% to 95% non-condensing
Water Resistance	100% waterproof
<b>Cable and Connector</b>	
RF	10 M RG-58 Cable
Cable Pulling Strength	12 Kg for 5 sec.
Connector	TNC (Standard)
<b>Physical Structure</b>	
RF	10 M RG-58 Cable
Dimensions	90.5 mm (Diameter) × 108.5 mm (H)
Weight	105 grams (without cable)



Picture 2-22 GPS antenna and mounting

## 2.2.8. GPS ANTENNA MOUNTING / OPTIONAL

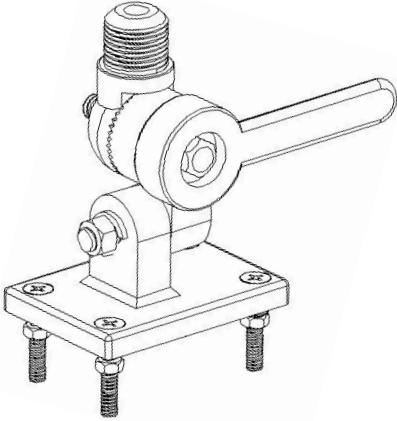

**Picture 2-23-1 GPS mounting**

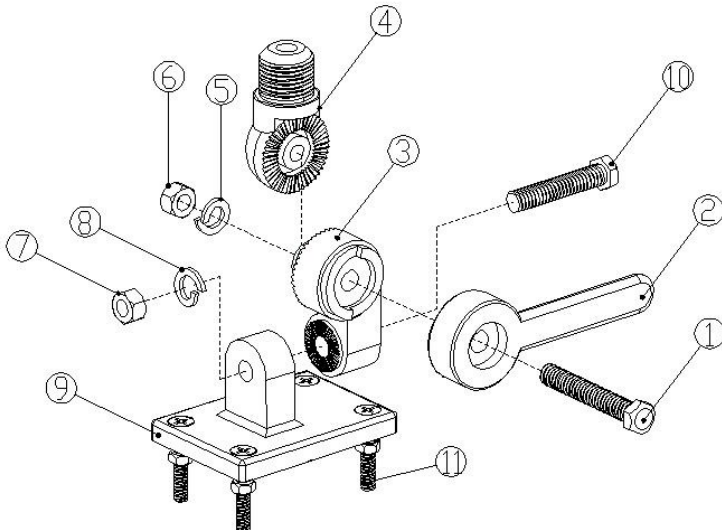

**Picture 2-23-2 GPS mounting**

- ① & ⑩ Hex Bolt
- ② Lever Bar
- ③ Rotation Hub
- ④ Rotation Mount
- ⑤ & ⑧ Washers
- ⑥ & ⑦ Nuts
- ⑨ Base plate
- ⑪ Mounting Bolts / Hardware (4 sets)

**Please follow the below steps to assemble the mounting:**

- A.** Put bolt ⑩ through the flat side of the rotation hub ③ and into the base plate ⑨ as shown. Place a washer ⑧ and nut ⑦ on the bolt and tighten the nut.
- B.** Put bolt ① through the lever bar ② and continue through to top part of rotation hub ③ into the rotation mount ④. Rotation mount ④ has a threaded portion. You must screw the bolt all the way in. Then back the bolt out 1-1 3/4 turns.  
\*If you fail to back the bolt out 1-1 3/4 times, the lever will not work.
- C.** Place washer ⑤ and nut ⑥ on bolt ① and tighten. Do not screw the bolt head in. Keep it stationary and tighten the nut only. Tighten the assembly by moving the lever counter-clockwise.
- D.** Mount your base plate in a desired location. Using the bolt ⑪ assembly. Loosen bolt ⑩ and adjust the unit so that the threaded portion is vertical. Tighten bolt ⑩.

## 2.3. CABLING

### 2.3.1. IMPORTANT NOTICE

When connecting the cables with CYPHO-101 Series, please ensure precaution are in place.

① Do not bend the cable or the antenna cable.

② Each coaxial cable should be set up separately and can only be set up in a single cable tube.

③ Each coaxial cable should keep a 10m safe distance from the power cable.

④ Connecting port of the coaxial cable should be insulated.

## 2.4. AMEC CYPHO-101(G) EXTERNAL CONFIGURATION

**\*There will be no GPS connector  
if the equipment is without internal GPS (CYPHO-101)**

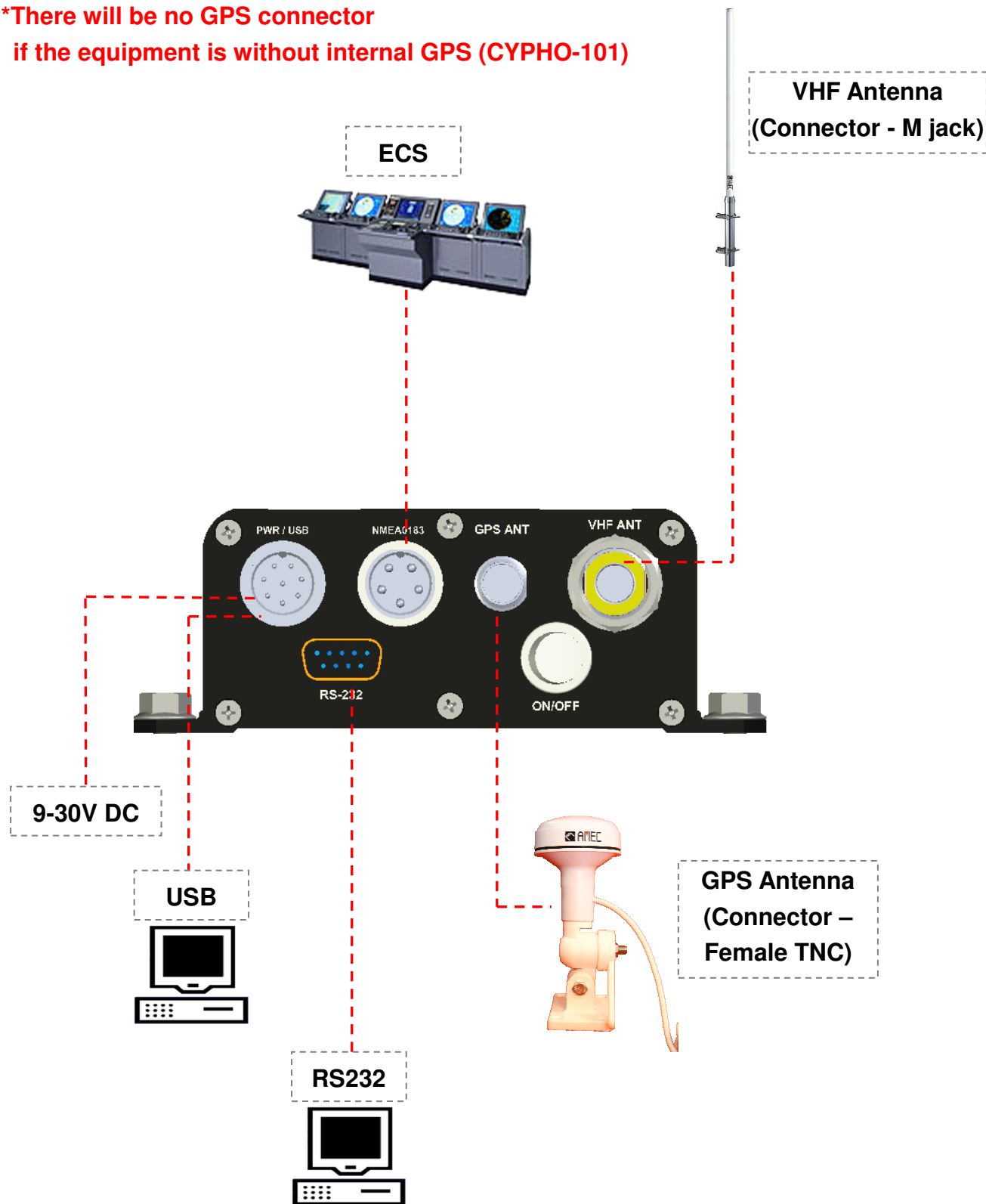

Picture 2-24 External configurations

### 2.4.1. ANTENNA LOCATION

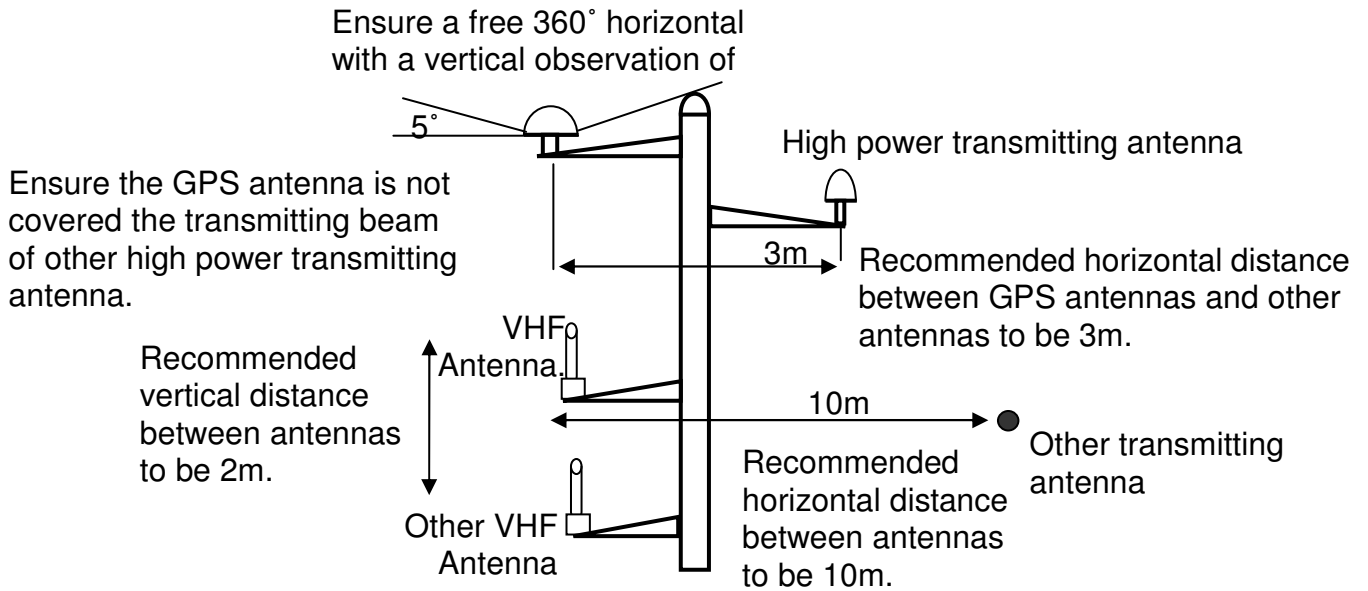

**Picture 2-25 Antenna location**



### 3. SOFTWARE INSTALATION

#### 3.1 INSTALL THE USB DRIVER

If you need to browse AIS information received by AMEC CYPHO-101 Series on computer via USB connector, please find the USB Driver on the located CD provided; and follow below steps to install the USB driver.

**Step 1:** Open the USB Driver file and double click on PL-2303 Driver Installer to install the driver.

Please click on to continue.

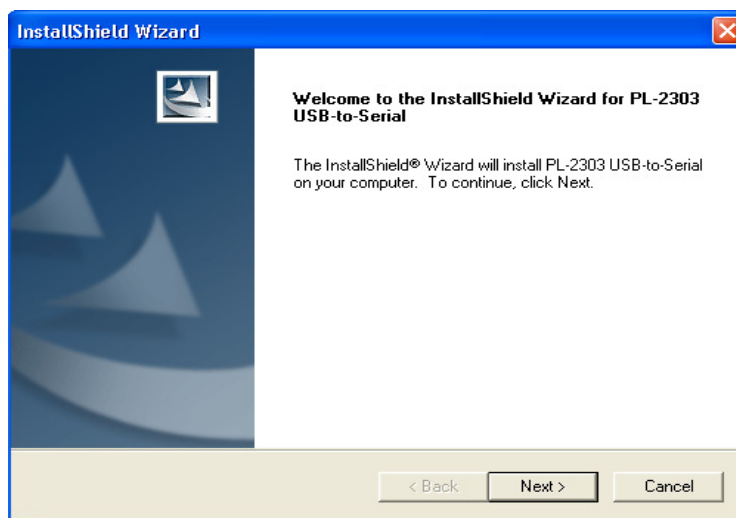

**Picture 3-1-1 USB driver installation**

**Step 2:** Please read the agreement carefully before the installation. If you accept the agreement, please click on to continue. This process will take a few minutes.

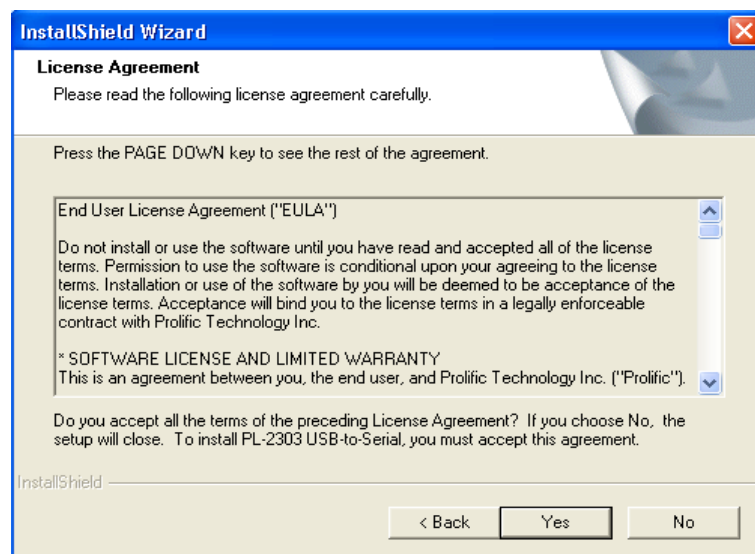

**Picture 3-1-2 USB driver installation**



**Step3:** The installation is completed; please click  to finish the installation.

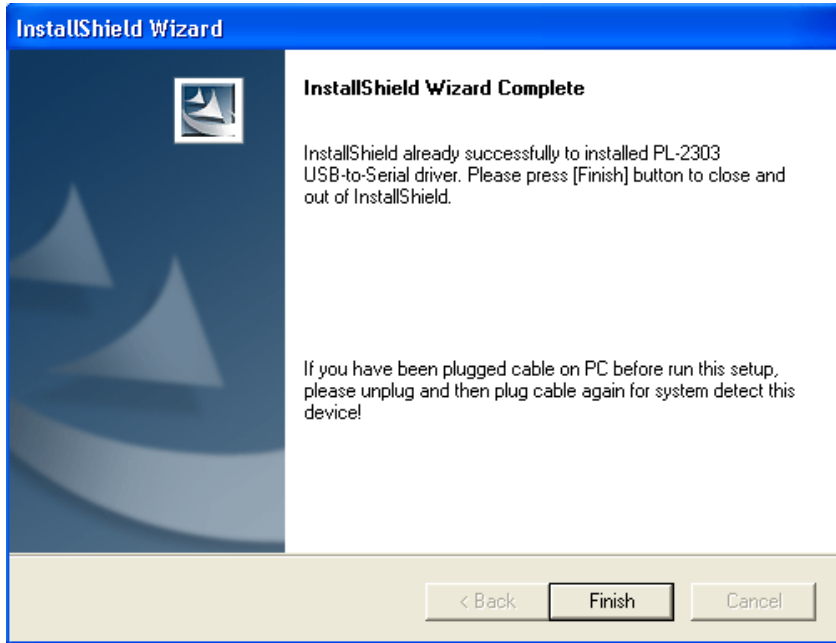

**Picture 3-1-3 USB driver installation**



### 3.2 CONFIGURATION (CYPHO-101 & CYPHO-101G only)

The configuration program enables users to select appropriate baud rate while connecting to other maritime equipments.

**Note: The pre-set baud rate of CYPHO-101 series is 38400 bps; connecting to other maritime equipment with 4800 bps may result in data loss.**

Please find the AMEC AIS Configue program on the CD provided; and follow below steps to configure your CYPHO-101 and CYPHO-101G.



**Step1:** Double click on

**Step2:** Select the suitable serial port and press  (see 5.1, page 42). Please press

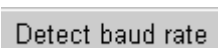
 to detect current baud rate setting.

\* The pre-set baud rate of the device is 38400 bps.

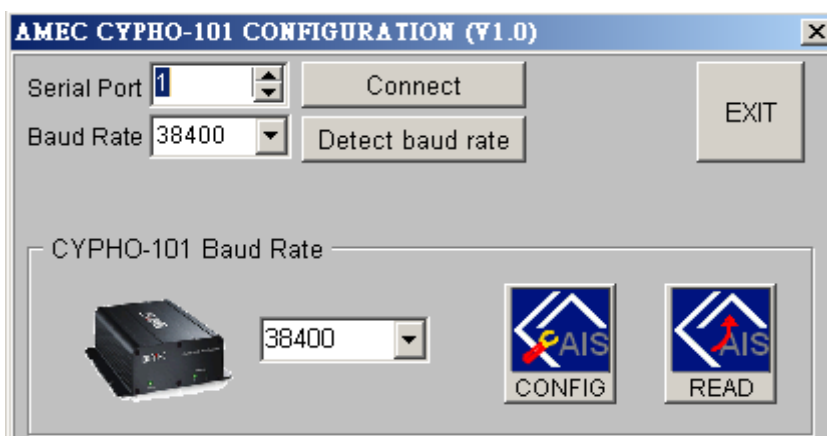

Picture 3-2-1 Serial Port Selecting



**Step3:** Select the desired baud rate and click  to save the setting, then click  to confirm the settings.

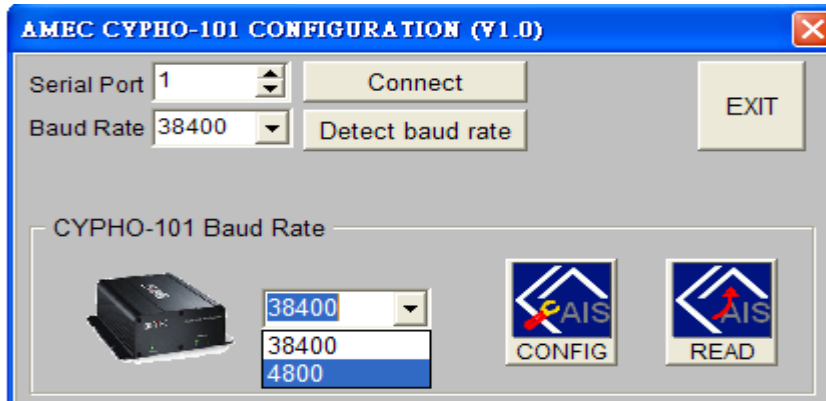

**Picture 3-2-2 Baud Rate Selection**

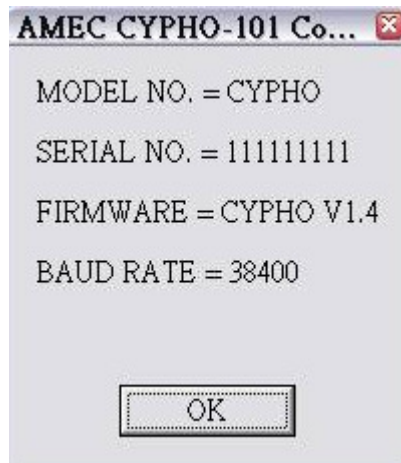

**Picture 3-2-3 Confirm Setting**



### 3.3. INSTALL THE AIS VIEWER ON PC

The viewer program provides users with AIS information on computer; users may browse the relative positions of surrounding vessels and the dynamic and static information regulated by IMO. For professional users or further details, we suggest you to connect AMEC CYPHO-101 Series with other marine electronic products such as ECS or Radar to achieve better performances.

Please find the AMEC AIS Viewer program on the CD provided; and follow below steps to install the viewer program.

**Step 1:** Please open the AMEC AIS Viewer file, and double click on

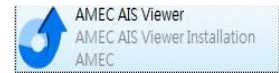

**Step 2:** Welcome window pops out, and click  to continue.

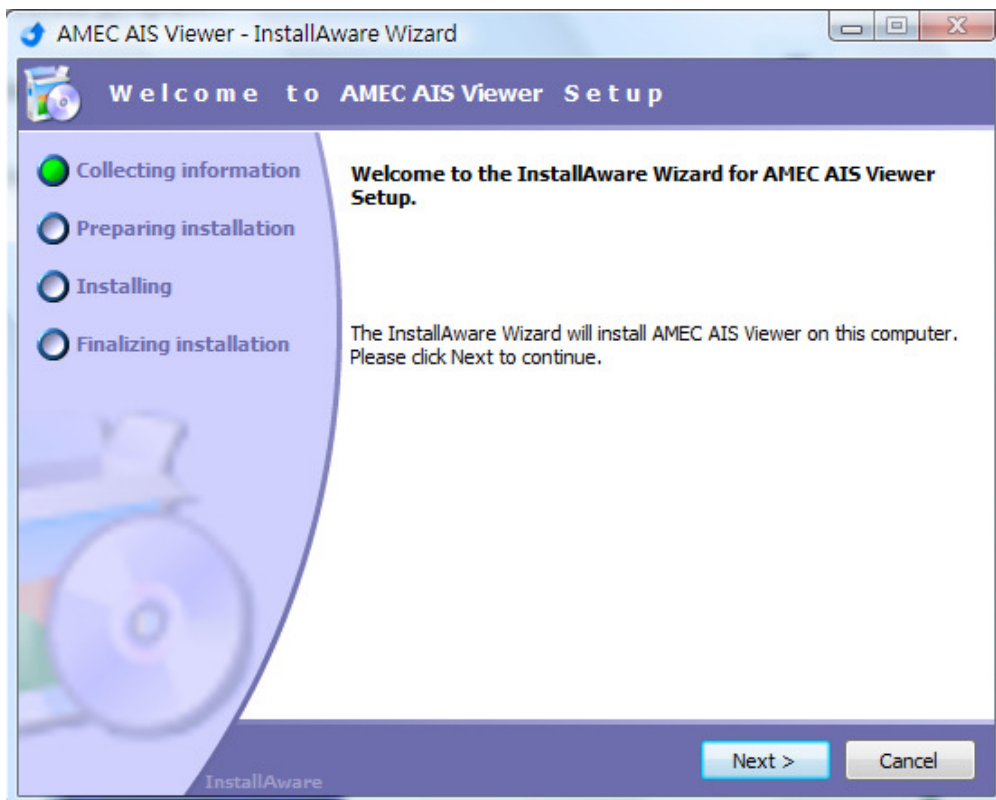

Picture 3-3-1 Set Up Viewer

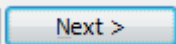

**Step 3:** Please fill in the required information and click  to continue.

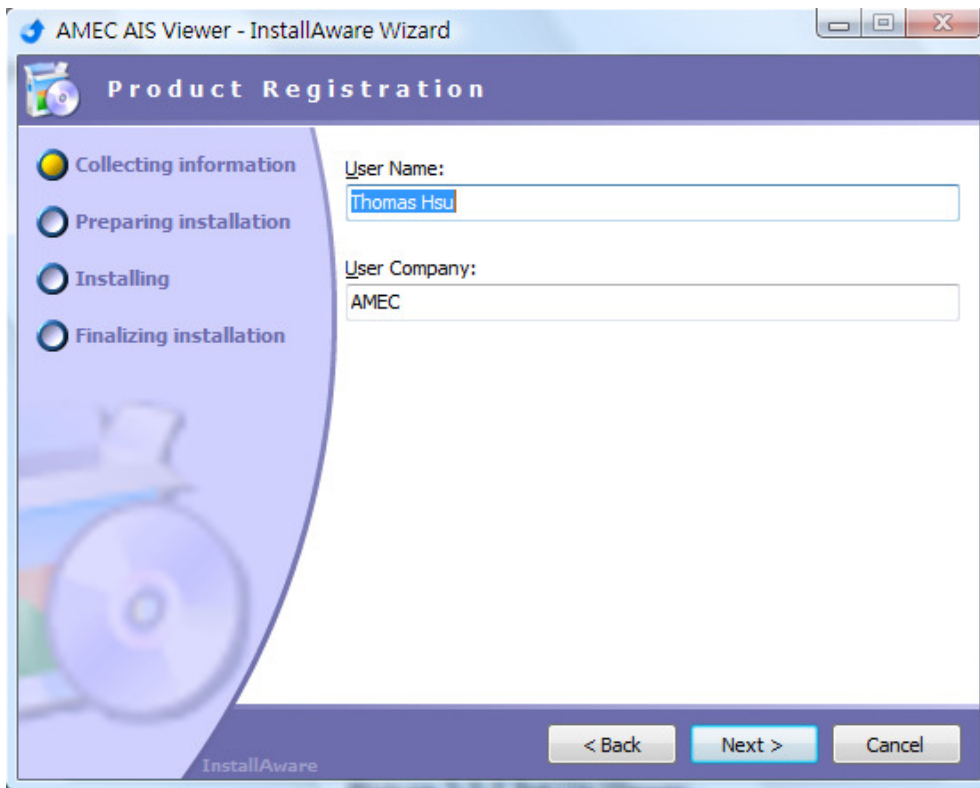

**Picture 3-3-2 Set Up Viewer**

**Step 4:** Please select a folder to install this viewer. Then click  to continue.

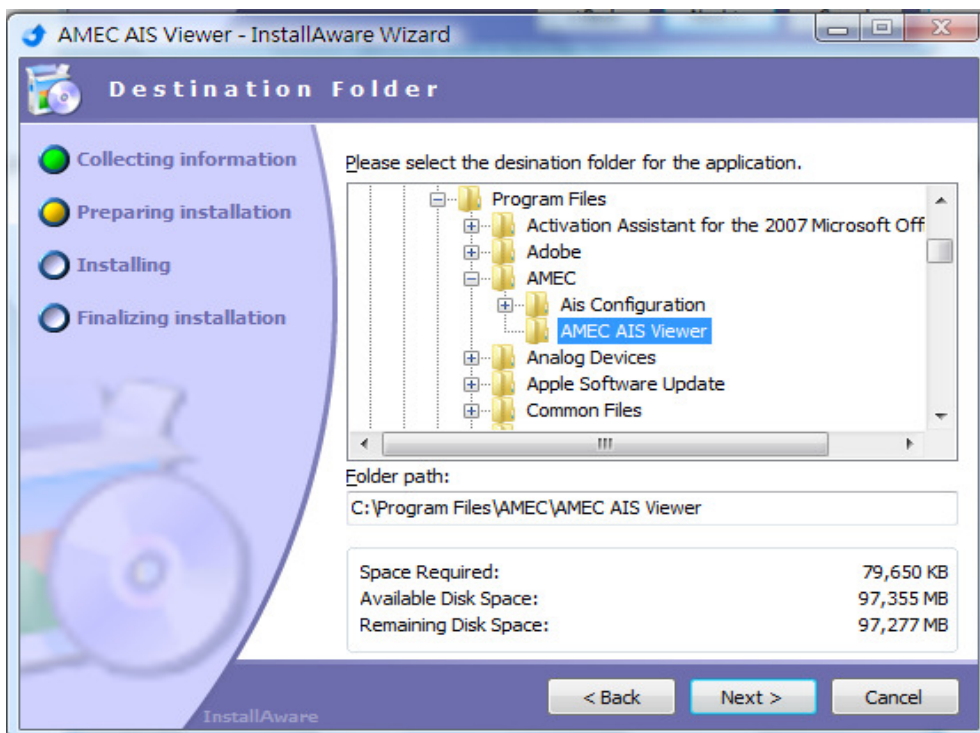

**Picture 3-3-3 Set Up Viewer**



**Step 5:** Please select your designated users for the shortcut and click

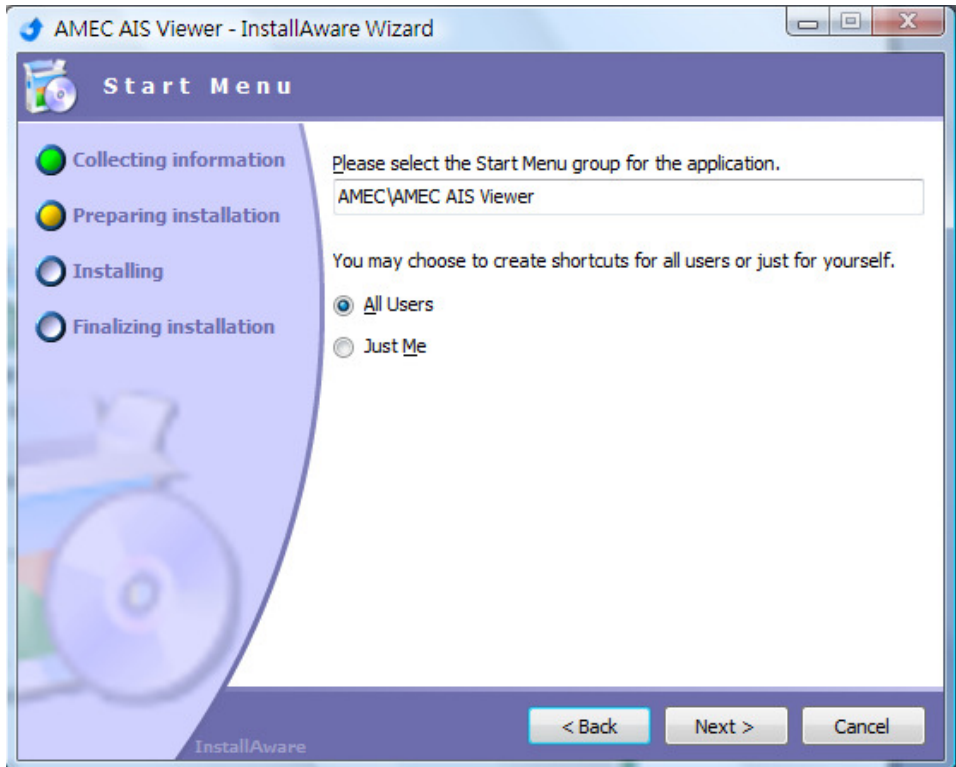
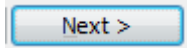

**Picture 3-3-4 Set Up Viewer**

**Step7:** The installation will take few seconds. When the installation is completed, please click  to complete the installation and run the program.

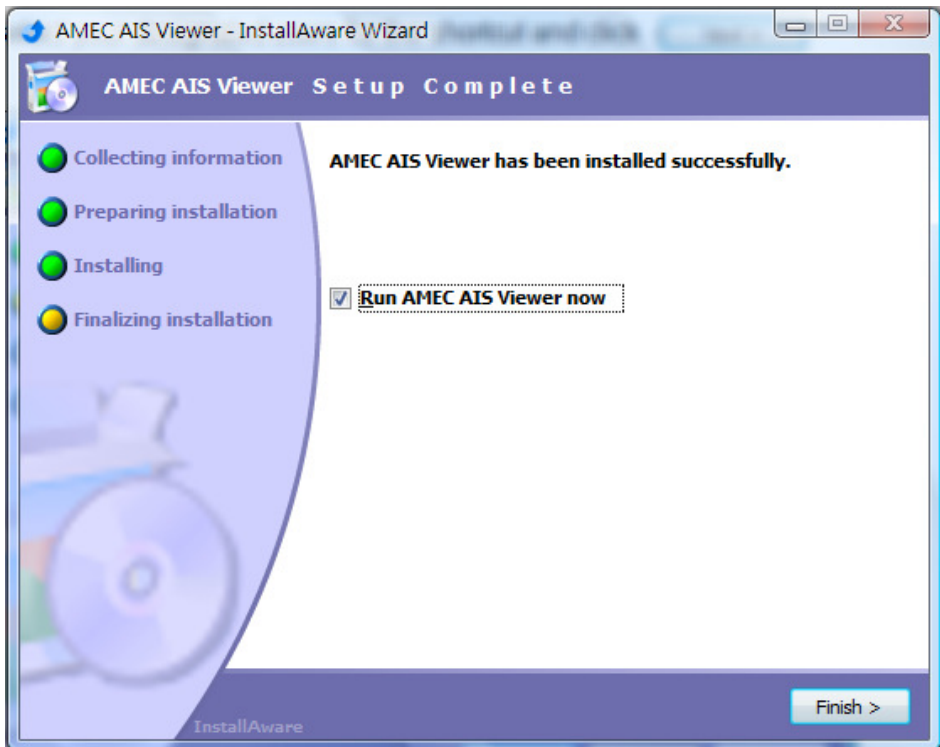

## 4. GET STARTED

### 4.1. FAMILIARIZE YOURSELF WITH THE FRONT PANEL AND ALL THE INDICATION LIGHTS

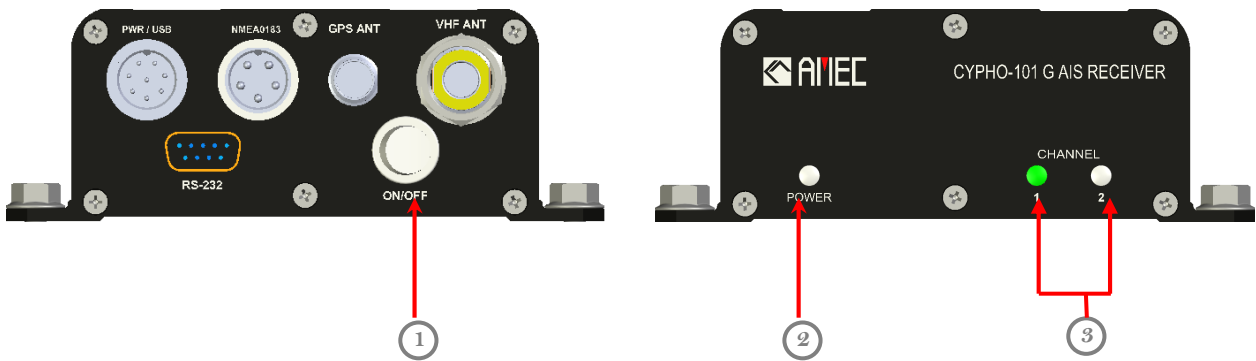

Picture 4-1 The Indication Lights

Table 4-1 Description of indication lights on front panel

1. Power	Power ON/OFF
2. Status	Indication light of power status
3. Channel 1/2	Channel 1 & 2 indication light

### 4.2. TURNING POWER ON / OFF

#### **TURNING POWER ON:**

**Step 1:** Check the input voltage. CYPHO-101 Series input voltage is 12 or 24 V DC (9-30V DC).

An adaptor is needed if the voltage supply is 110V AC or any other voltage.

**Step 2:** Connect the CYPHO-101 Series with power input.

**Step 3:** Switch the power to “ON”.

**Step 4:** The status indication light will turn to green from flashing green light.

**Step 5:** When the power status indication light turns green, the unit will function automatically.

The channel indication light flashes once the signal is received.

#### **TURNING POWER OFF:**

**Step 1:** Switch the power to “OFF”.

**Step 2:** The unit shuts down and status off.

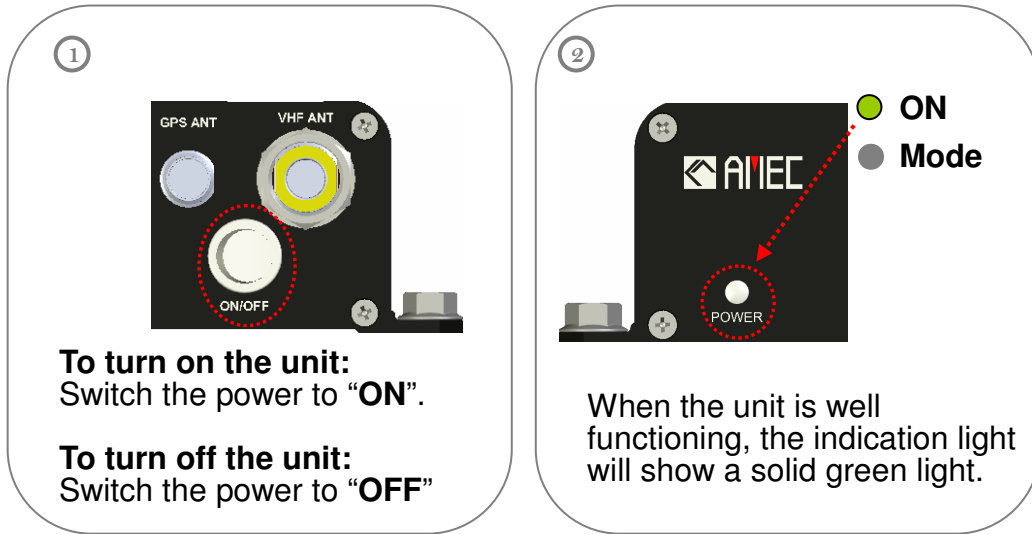

Picture 4-2 Description of Power Switch & Indication Light

Table 4-2 Power Status Indication Light

POWER STATUS INDICATION LIGHTS			
Color	Status	Indications	Descriptions
Green	ON	Normal	N/A
	Flash	Power error	Check for power connection and power voltage (9-30 V DC)

Table 4-3 Channel indication light

CHANNEL INDICATION LIGHTS		
Channel	Status	Indications
1	Flash	Incoming data received at Channel 1.
2	Flash	Incoming data received at Channel 2.



## 5. AIS VIEWER APPLICATION GUIDE

### 5.1. Serial Port Setting

Please follow below steps to ensure the serial port is correctly selected if needed. (Below is the USB example. RS232 would be in the same connection way if desired).

1. Please install the USB driver in advance, and use USB cable to connect with PC and AMEC AIS if desired. There will be no other installation software required if using RS232.
2. Go to My Computer/Control Panel/System/Hardware/Device Manager/Port (Com&LPT) after software installation finished.
3. Find and click the Ports (Com&LPT) and choose the prolific USB-to.Serial Comm Port (Com3) as designated port numbers as below chart shown.

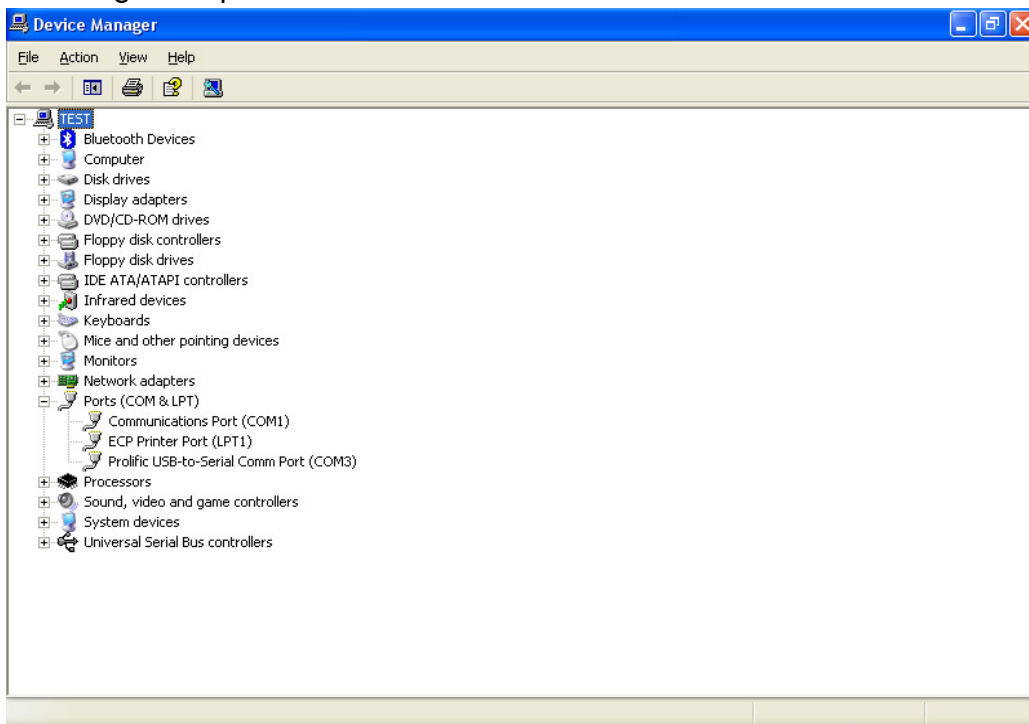

Picture 5-1Serial Port Setting

4. Back to the “**Config**”, and click AIS serial port. Please select the suitable serial port number in the pop out window.



## 5.2. AMEC AIS VIEWER QUICK START

Please find the AMEC AIS Viewer program on the CD provided; and follow below steps to start your CYPHO-101 and CYPHO-101G.

**Step 1:** Please select appropriate Serial Port and Baud Rate, and click  to complete the settings.

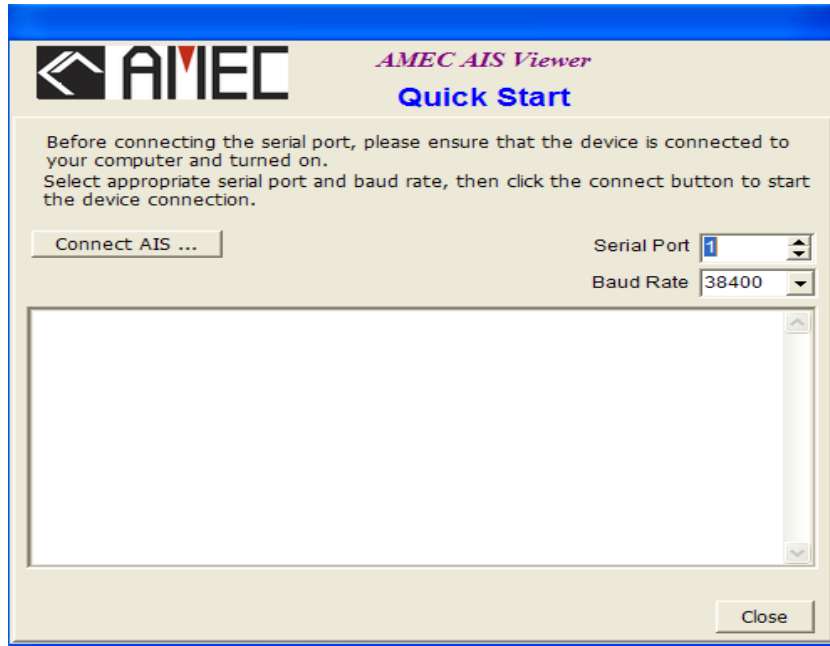

Picture 5-2-1 Quick Start

**Step 2:** After clicking , the settings will be displayed as below. Then click  to start the viewer program.

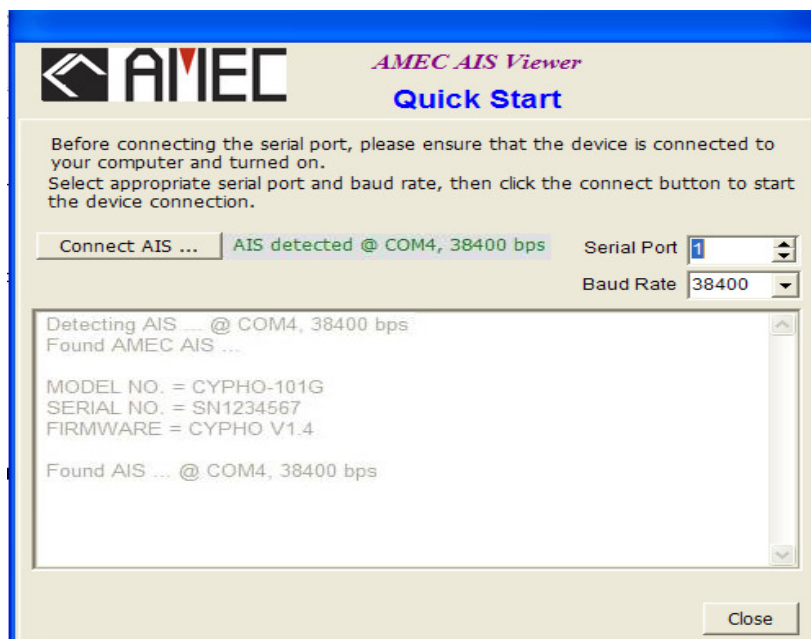

Picture 5-2-2 Quick Start View

### 5.3. AMEC AIS VIEWER RADAR VIEW

The AIS targets are displayed on your PC screen in the form as shown below. The data are generated from the vessels in the surrounding sea. These data have various indications and do not stay in the same status at all times.

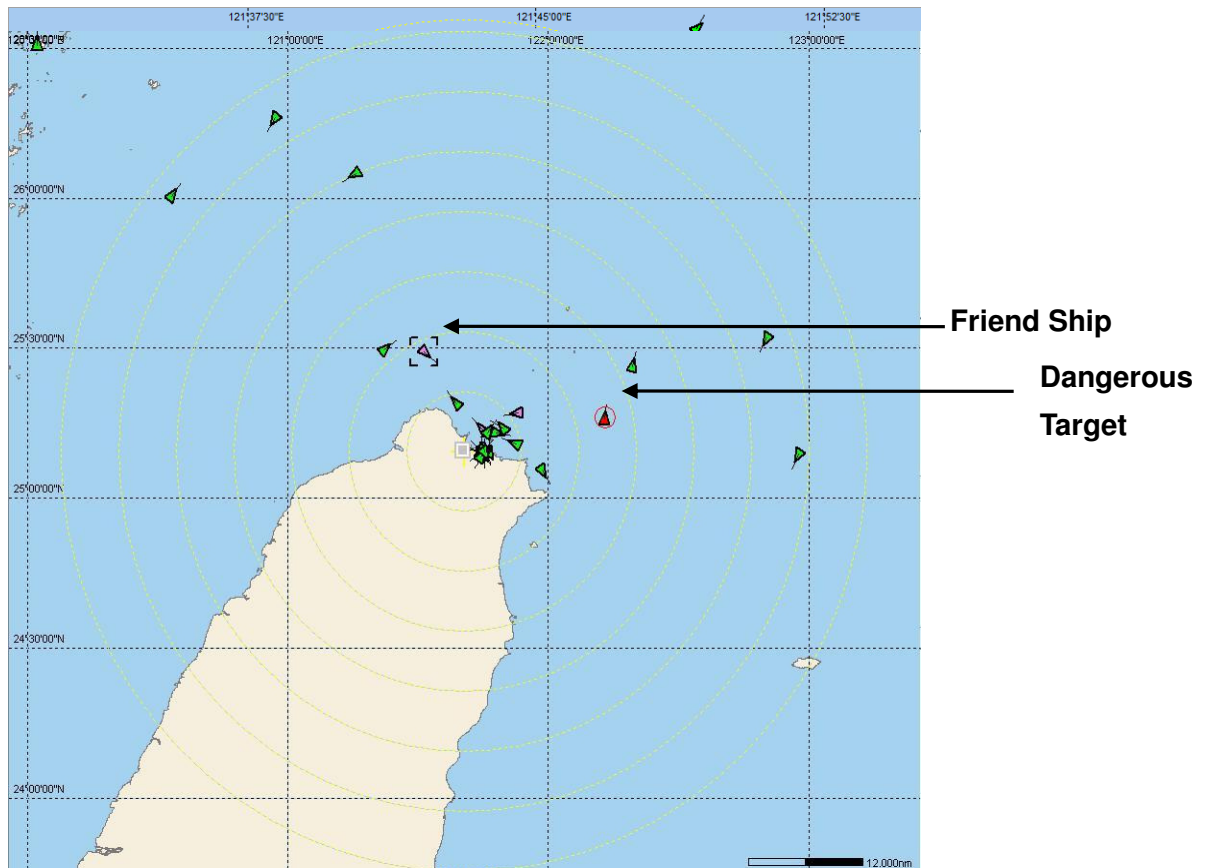

**Picture 5-3-1 Main Display**







On the radar plotter shown above, some characteristics of the AIS targets are as described below:

- Each AIS target is in the shape of a triangle and stands for one ship only.
- Under normal GPS reception, own ship is located in the center of the radar view.
- When there is no GPS reception, you can manual reset your own ship's longitude and latitude or allow the viewer to reset according to the received targets for predicting the location of the own ship and a reference location.
- A maximum number of 500 AIS targets can be displayed on the radar plotter at a time.

### 5.3.1. AIS TARGET SYMBOL DESCRIPTIONS

Symbol for each AIS target displayed on the radar plotter is as described below.

**Table 5-1 AIS target symbol**

<b>Own Ship</b> 	<b>GPS Reception: Normal / Color: Gray</b> Under normal GPS reception, own ship is in color gray.
<b>Own Ship</b> 	<b>GPS Reception: None / Color: Gray</b> If there is no GPS signal, users may manually input LON/LAT; otherwise the system will produce a reference position based on surrounding vessels data.
<b>AIS Target</b> 	<b>Color: Green</b> Ships with AIS in the surroundings will appear in GREEN.
<b>Selected Target</b> 	<b>Flashing Black Frame</b> Select any target on the screen; detailed information of specific target can be viewed when selected.
<b>Dangerous Target</b> 	<b>Color: Red / Circled Frame</b> If the distance to certain ships is less than CPA/TCPA, the target will appear with a red circle. Users may select the dangerous target and view the detailed information.
<b>Friend Ship</b> 	<b>Color: Pink</b> If any pre-stored Friend Ship is nearby, the Friend Ship will appear in the color of PINK on the radar plotter.
<b>Lost Signal Target</b> 	<b>Color: Green / Crossed</b> If reception of any AIS target breaks over for 10 minutes, then a "x" will be displayed and then disappear after an hour.

- The straight line extended from AIS target represents the course of the ship.



## 5.4. Quick Start

The following steps allow you to start the AIS Viewer in a very short time after all the installations are completed:

**Step 1:** Open the viewer and go to “**Config**”→ Select “**AIS Serial Port**” to set the serial port (Refer to **Picture 5-4-1**). Please refer to **P. 51 “AIS Serial Port”** for more details.

**Step 2:** If the connections for the viewer and external GPS are required, please go to “**Config**”→ Select “**GPS Serial Port**” to set the serial port (Refer to **Picture 5-4-1**). Please refer to **P. 52 “GPS Serial Port”** for more details.

**Step 3:** Go to “**Config**”→ Select “**CPA/TCPA**” to set the distance and the time (Refer to **Picture 5-4-1**). Please refer to **P. 53 “CPA/TCPA”** for more details.

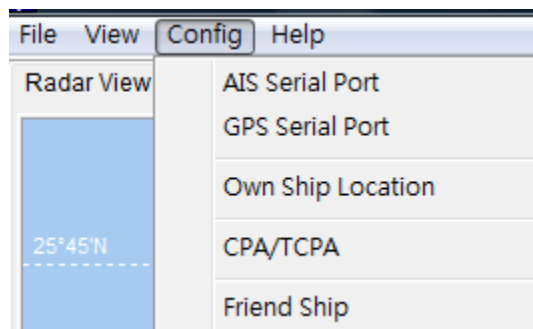

**Picture 5-4-1 Quick Start**

**Step. 4:** Go to “**File**” and click on “**Connect AIS**” and “**Connect GPS**” (Refer to **Picture 5-4-2**).

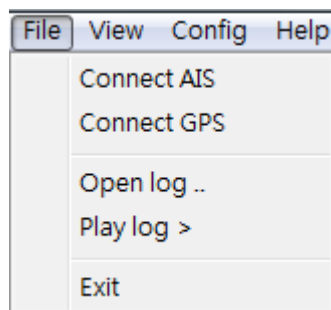

**Picture 5-4-2 Quick Start**

After above 4 steps completed, you may start to use the AIS Viewer.

## 5.5. MAIN DISPLAY

Below (**Picture 5-5-1**) is the main screen of the viewer, which contains 5 blocks. Each block displays different information. Please see details:

**Block 1:** There are 4 setting / function keys and 2 viewing mode options in this section. (Refer to **Picture 5-5-1.**) Please complete the system settings and the function connecting before you started to use the viewer.

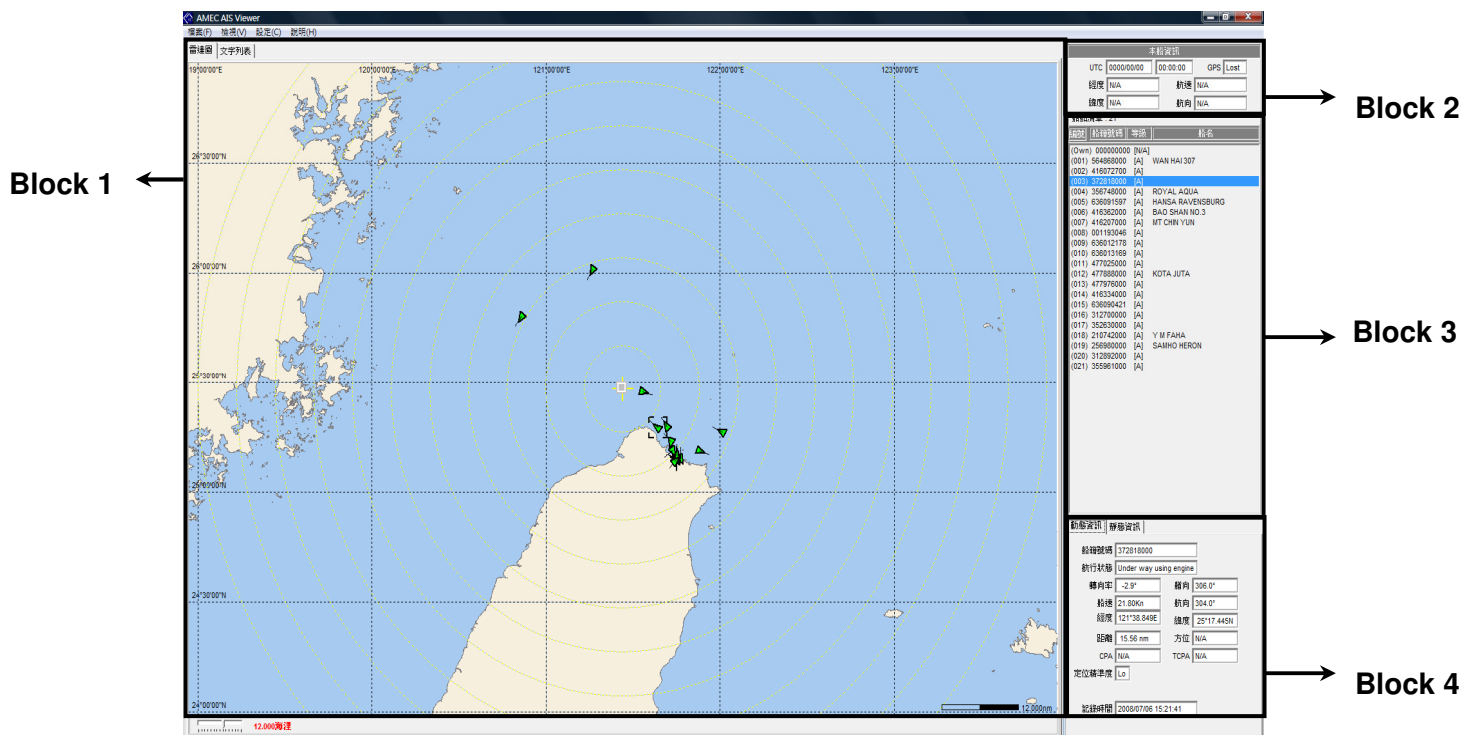

Picture 5-5-1 Main Display



1. **File**: Click on “**File**”, you will see the window as following. (Refer to **Picture 5-5-2**)

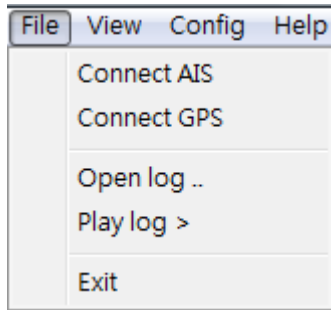

**Picture 5-5-2 Main Display**

“**Connect AIS**”: Click on “**Connect AIS**” to link the viewer and AMEC CYPHO-101Series.  
Please refer to **P. 51 “AIS Serial Port”** for related settings.

“**Connect GPS**”: Click on “**Connect GPS**” to feed external GPS data to the viewer.  
Please refer to **P. 52 “GPS Serial Port”** for related settings.

“**Open log**”: Click on “**Open log**” to open the data saved before.

“**Play log**”: Click on “**Play log**” to play the selected log data.

NOTE: Before you play the log data, you should go to “**File**”/ “**Disconnect AIS**” and “**File**”/ “**Disconnect GPS**” to disconnect AIS and GPS. Please refer to **Picture 5-5-3**.

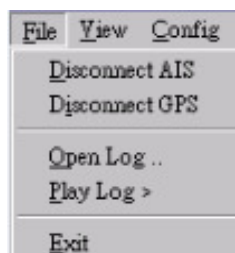

**Picture 5-5-3 Main Display**



\*\*\*If you need to pause or stop the play, please go to “File”/ “Pause play” or “File”/ “Stop play”. Please refer to **Picture 5-5-4**.

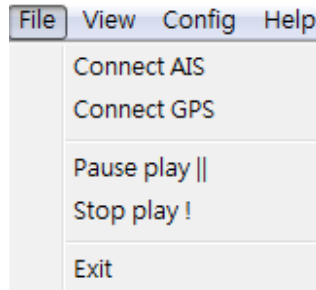

**Picture 5-5-4 Main Display**

“Exit”: Click on “Exit” to close AMEC AIS Viewer.

2. **View**: Click on “View”, you will see the window as following. (Refer to **Picture 5-5-5**)

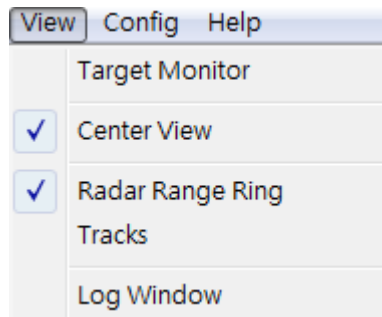

**Picture 5-5-5 Main Display**

“Target Monitor”: Click on it to monitor the vessel information of the selected target. Under this mode, the Radar Viewing in Block 1 also Block 3 and Block 4 would monitor the same target (Refer to **P. 47 Block 3** and **P. 47 Block 4**).

“Center View”: There are two scenarios under this viewing mode, 1) without GPS data input 2) with GPS data input. Without GPS input, you may select this viewing mode; the viewer would calculate the rough position and set your own ship at the center of the Radar display. You may also set your own ship position manually (refer to **P.52 “Own Ship Location”**). Please refer to **P. 55 “Radar View”** for more viewing options. Under the situation with GPS input, the viewer will set your own ship as the center of the Radar display automatically and the “Center View” would be invalid.



“**Radar Range Ring**”: You could check this item if you like to have radar rings on the screen.

“**Tracks**”: Click on it, to see the tracks of the monitor vessels.

“**Log Window**”: Click on “**Log Window**”, you will see the window as following (Refer to **Picture 5-5-6**). Tick “**Enable Log**” to display the collected data in the box. Click on  to save the data, click on  to delete it.

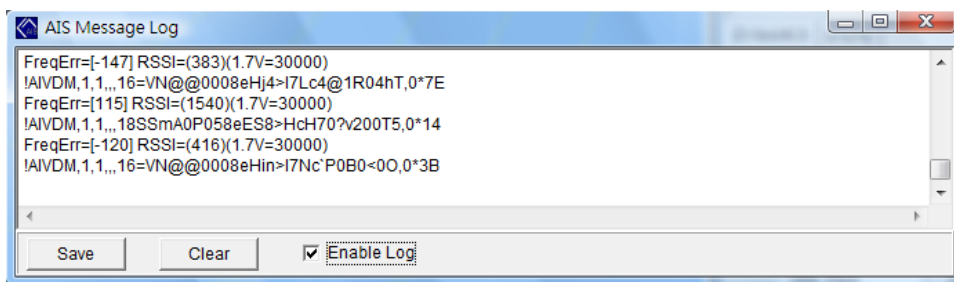

**Picture 5-5-6 Main Display**

3. **Config:** Click on “**Config**”, you will see the window as following. (Refer to **Picture 5-5-7**)

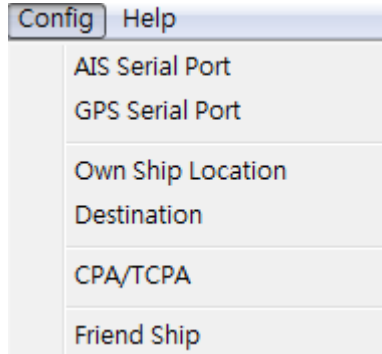

**Picture 5-5-7 Main Display**

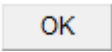
“**AIS Serial Port**”: Click on “AIS Serial Port” the “Config AIS Serial Port” window would pop out (Refer to **Picture 5-5-8**). In this window, except “Serial Port” and “Baud Rate”, all parameters are default, which can not be changed (CYPHO-101E). Please choose a suitable “Serial Port” and a suitable “Baud Rate” (Receiver: 38400; Class B AIS: 115200). Click on  to complete the setting.

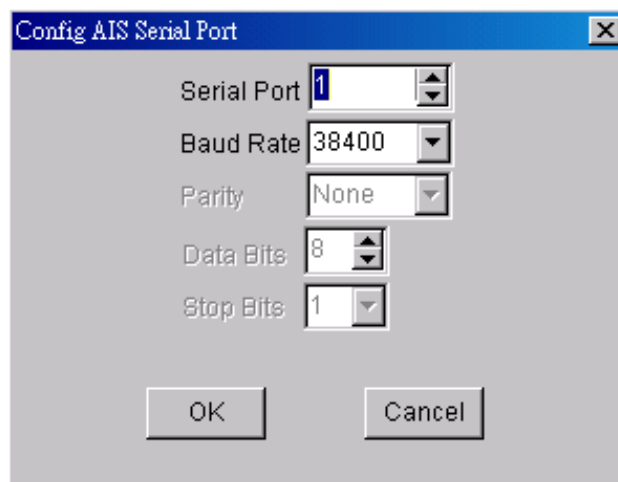

**Picture 5-5-8 Main Display**

**“GPS Serial Port”**: Click on “GPS Serial Port” the “Config GPS Serial Port” window would jump out as below (Refer to **Picture 5-5-9**). Please select a suitable “Serial Port”. Please refer to the manual of your GPS device to complete the rest setting. Click on  to complete the setting.

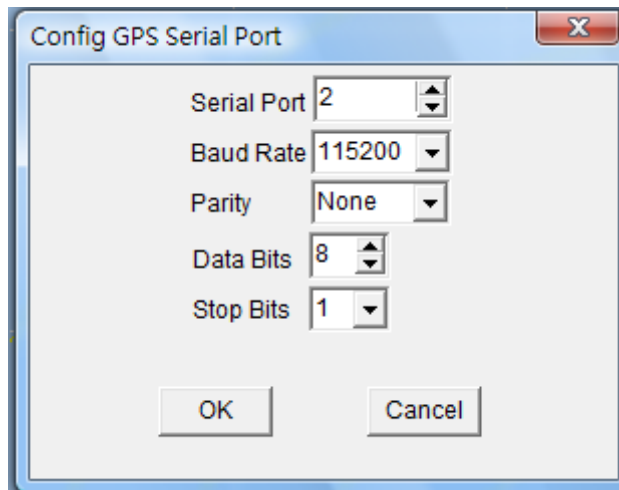

**Picture 5-5-9 Main Display**

**“Own Ship Location”**: You can manually enter the position of your vessel as the center of the Radar display when GPS is malfunction (Refer to **Picture 5-5-10**). Click on  to complete the setting.

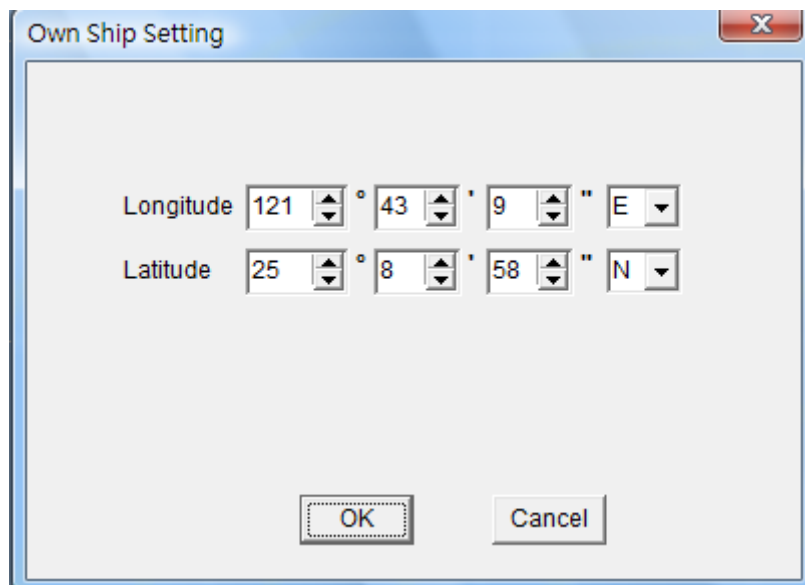

**Picture 5-5-10 Main Display**

**“Destination”** Click on “Destination” the “Destination Setting”. A window will appear as below (Refer to **Picture 5-5-11**). You could enter the name, the longitude and the latitude of you destination. After that please click on  to complete the setting, then you will see a red pin pinned on your destination.

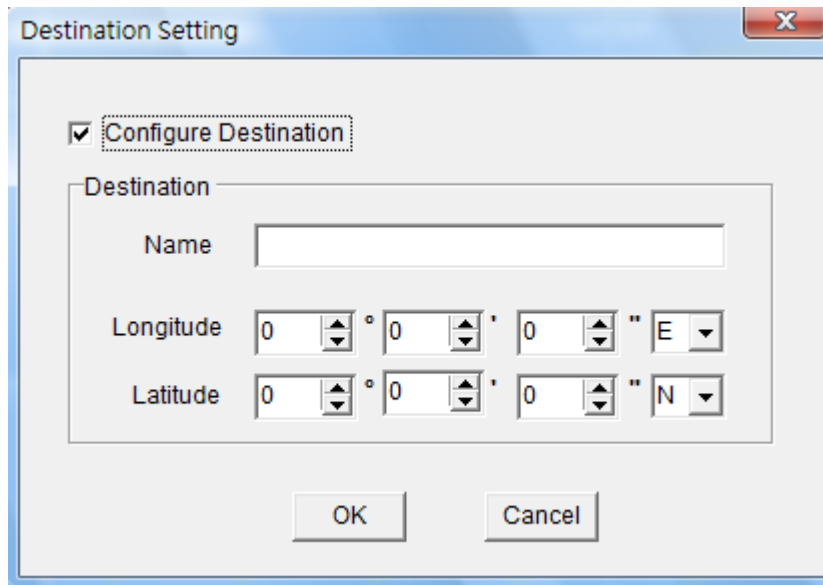

**Picture 5-5-11 Main Display**

**“CPA/TCPA” (Distance to Closest Point of Approach/Time to Closest Point of Approach):** Click on “CPA/TCPA”. A window appears as below (Refer to **Picture 5-5-12**). In this window, you can set the CPA and TCPA according to your requirement. When a ship is entering the alert area, it would be indicated in red (Refer to **Section 5.3 and 5.3.1**). Click on  to complete the setting.

- nm: Nautical Mile
- min: Minute

**\*Note: This function will be invalid without GPS data input.**

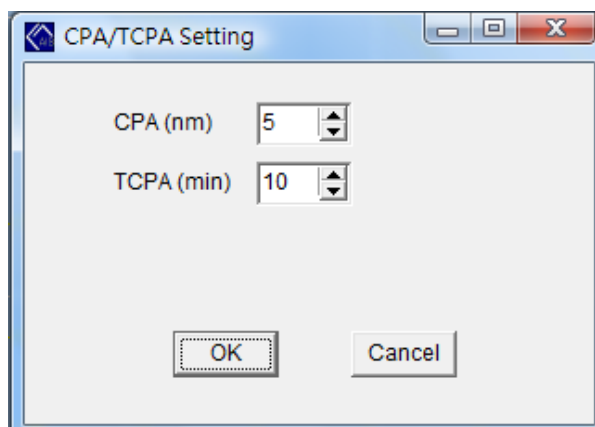

**Picture 5-5-12 Main Display**

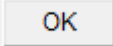

**“Friend Ship”**: Click on “Friend Ship”, the window would jump out as below (Refer to **Picture 5-5-13**). In this window, you can set specific ships as your friend ships. Simply enter the MMSI number and a “Y” at “Friend” column; the icon of the selected targets will turn to pink in the Radar display (Please refer to **Section 5.3 & 5.3.1**). Click on  to complete the setting.

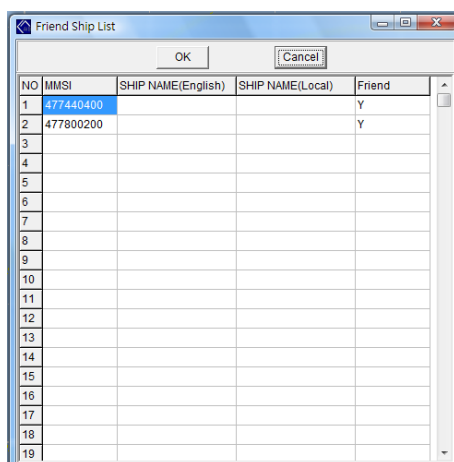

**Picture 5-5-13 Main Display**

4. **Help**: Click on “Friend Ship” the window will jump out as below (Refer to **Picture 5-5-14**).

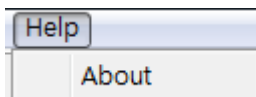

**Picture 5-5-14 Main Display**

**“About”**: Click on “Friend Ship”. A window appears as below shown. (Refer to **Picture 5-5-15**). It contains the related information of the software including the established date and the version. The software would be updated periodically, if any; which can be free downloaded on AMEC website, [www.alltekmarine.com](http://www.alltekmarine.com).

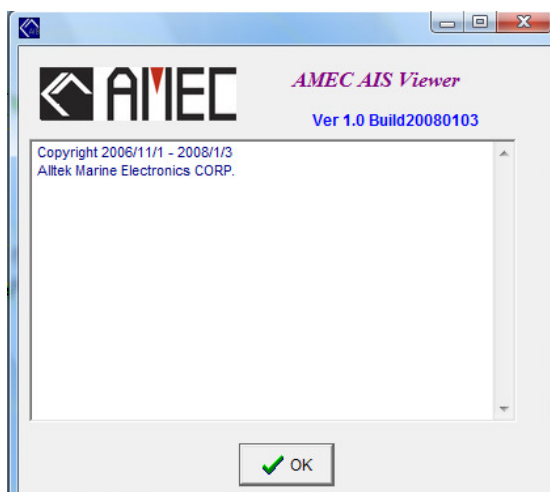

**Picture 5-5-15 Main Display**

**“Radar View”**: In this viewing mode, all targets will be displayed on the Radar display (refer to **Picture 5-5-16**). Please refer to **Section 5.3.1 AIS TARGET SYMBOL DESCRIPTIONS** for the definition of the icons.

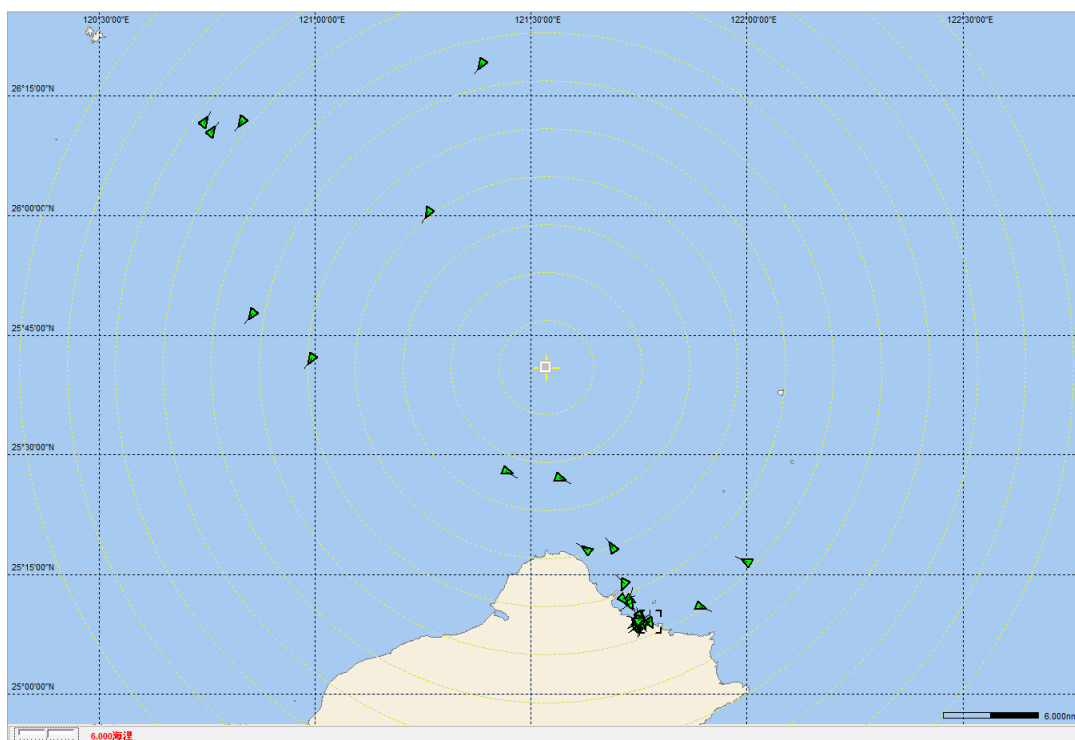

**Picture 5-5-16 Main Display**

- The own ship will show at the center of the Radar display as the default value when there is **NO** GPS data input. Please refer to **P. 55 “Center View”**.
- Under the situation of **NO** GPS data input, double click at any position on the Radar display to make it as the center.  
**\*Own ship position will be fixed at the center of the Radar display WITH GPS data input.**
- Please use the scale to change the scale setting at the lower left corner if needed. These setting are shown in the scale at the lower right corner. The scales are 12nm, 6nm, 3nm, 1.5nm, 0.75nm, 0.5nm, 0.25nm, 0.125nm and 0.05nm.



“**Alphanumeric View**”: Under this mode, all ship details will be displayed alphanumerically. This information is extensive, if you want to view it all, please use the bar on the screen. (Refer to **Picture 5-5-17**)

NO	MMSI	CLASS	NAME	CALLSIGN	RANGE	BEARING	SOG	COG	HEADING	CPA	TCPA	LON	LAT	ROT	LENGTH
Own	000000000	[N/A]		N/A	0.00 nm	0.0°	0.01kn	N/A	N/A	0.00 nm	0.0 min	121°43.188E	25°08.978N	N/A	0m
1	431830000	[A]	CRUIS FERRY7MGD		1.65 nm	N/A	0.00Kn	44.0°	31.0°	1.22 nm	11136.1	121°44.613E	25°07.974N	0.0°	167m
2	538090067	[A]	CAPE CAMPBIV7DZ6		1.66 nm	N/A	0.00Kn	234.9°	231.0°	0.76 nm	14770.5	121°44.920E	25°08.490N	3.6°	135m
3	004163100	[BASE]		N/A	2.16 nm	N/A	N/A	N/A	N/A	0.23 nm	21492.9	121°45.462E	25°09.577N	N/A	N/A
4	477440400	[A]	TASMAN PROVRAE3		1.87 nm	N/A	0.00Kn	0.1°	240.0°	0.85 nm	16621.2	121°45.140E	25°08.428N	0.0°	185m
5	352493000	[A]	ACX SATSUMA3EMU6		11.81 nm	N/A	10.40Kn	130.5°	131.0°	Pass	Pass	121°56.210E	25°08.725N	731.4°	123m
6	477800200	[A]	JJ NAGOYA VRAL7		1.72 nm	N/A	0.00Kn	0.1°	241.0°	0.29 nm	16985.8	121°45.072E	25°08.986N	0.0°	135m
7	636091171	[A]	JPO SCORPILABKCB		1.86 nm	N/A	0.00Kn	201.0°	353.0°	0.52 nm	17822.0	121°45.207E	25°08.774N	0.0°	210m
8	352388000	[A]	BUENA SUN@3FAH5@C		1.80 nm	N/A	0.10Kn	276.3°	N/A	0.13 nm	1016.4 n	121°45.125E	25°08.681N	731.4°	105m
9	309589000	[A]			14.46 nm	N/A	13.30Kn	30.2°	46.0°	Pass	Pass	121°50.824E	25°21.671N	720.0°	0m

BEAM	DESTINATION	ETA	SHIPTYPE	CARGO
0m		0/0 00:00	(0)Undefined sh	(0)N/A; Harmles
28m	INCHEON@@	11/3 17:30	(70)Cargo ship	(70)N/A; Harmle
23m	KEELUNG	11/1 15:00	(70)Cargo ship	(70)N/A; Harmle
0m		0/0 00:00	(0)Undefined sh	(0)N/A; Harmles
16m	KEELUNG@@	10/31 22:40	(71)Cargo ship	(71)DG,HS or Mll
0m		0/0 00:00	(0)Undefined sh	(0)N/A; Harmles
0m		0/0 00:00	(0)Undefined sh	(0)N/A; Harmles
0m		0/0 00:00	(0)Undefined sh	(0)N/A; Harmle
27m	TAICHUNG	11/2 01:00	(70)Cargo ship	(70)N/A; Harmle
23m	KEELUNG	9/30 08:00	(33)Vessel-Drec	(33)Unknown C:

**Picture 5-5-17 Main Display**

- **MMSI: Marine Mobile Service Identity.**
- **CLASS: AIS Message Type ; [A]:Class A AIS, [B]: Class B AIS, [Base]: Base Station, [AtoN]: Aid to Navigation, [N/A]: Unknown.**
- **NAME: Ship Name.**
- **CALL SIGN: Ship’s Call Sign. There is no ship call sign if the cell is left in blank.**
- **RANGE: The distance between target ship to own ship. Using “nm” (Nautical Mile) to represent.**
- **BEARING: The relative angle between target ship and own ship.**
- **SOG: Speed Over Ground, using kn (knot) to represent.**
- **COG: Course Over Ground.**
- **HEADING: The heading of the target ship.**
- **CPA: Distance to Closest Point of Approach, using nm (Nautical Miles) to represent.**
- **TCPA: Time to Closest Point of Approach, using min (Minutes) to represent.**
- **LON: Longitude of the target ship.**
- **LAT: Latitude of the target ship.**
- **ROT: Rate Of Turn.**
- **LENGTH: The length of the target ship, using m (meters) to represent.**
- **BEAM: The beam of the target ship, using m (meters) to represent.**
- **DESTINATION: The destination of the target ship.**
- **ETA: Estimated Time of Arrival, (Month/Date/Hour/Minutes)**
- **SHIPTYPE: Ship type of the target ship.**
- **CARGO: Cargo information.**



**Block 2:** The own ship information is displayed in this section (refer to **Picture 5-5-18**). Please go to **P. 56 “Alphanumeric View”** for details if needed.

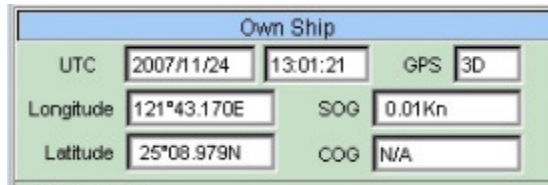

**Picture 5-5-18 Main Display**

- **UTC:** Coordinated Universal Time.
- **GPS:** GPS related information. Usually it would indicate 2D or 3D to show the accuracy of the GPS data. (3D is more accurate)
- **Longitude:** Current Longitude of own ship.
- **Latitude:** Current Latitude of own ship.
- **SOG:** Speed Over Ground of the own ship.
- **COG:** Course Over Ground of the own ship.

**Block 3:** The MMSI of the target ships and their static are shown as below. (Refer to **Picture 5-5-19**). Please go to **P. 56 “Alphanumeric View”** for details if needed.

SHIP LIST : 20			
NO.	MMSI	CLASS	NAME
(Own)	00000000	[N/A]	
(001)	431830000	[A]	CRUIS FERRY HIRYU21
(002)	538090067	[A]	CAPE CAMPBELL
(003)	004163100	[BASE]	
(004)	477440400	[A]	TASMAN PROVIDER
(005)	352493000	[A]	ACY SATSUMA
(006)	477800200	[A]	JUNAOIYA
(007)	636091171	[A]	JPO SCORPIUS
(008)	352388000	[A]	BUENA SUN@@@@@@@@@
(009)	309589000	[A]	
(010)	441401000	[A]	MV GOLDEN MERCHANT
(011)	416123000	[A]	ASIA CEMENT NO2@@@@
(012)	235612000	[A]	HATSU PRIDE
(013)	376634000	[A]	FU SHUN
(014)	416207000	[A]	CHIN YUN@@@@@@@@@
(015)	477672000	[A]	JIN HAI HU
(016)	357673000	[A]	ECOPROGRESS@@@@@@@@
(017)	477928000	[A]	TAI SHUN@@@@@@@@@
(018)	416109500	[A]	
(019)	376817000	[A]	YEN MEN@@@@@@@@@
(020)	416397000	[A]	KAIHO NO.8@@@@@@@@@

**Picture 5-5-19 Main Display**

- **SHIP LIST:** The number shows here is the number of received targets, excluding the own ship.
- **NO.:** The order number of the received targets.
- **MMSI:** Maritime Mobile Service Identity.
- **CLASS:** It shows the AIS message type of received targets; [A]:Class A AIS, [B]: Class B AIS, [Base]: Base Station, [AtoN]: Aid to Navigation, [N/A]: Unknow.
- **NAME:** The name of the target ship.
- The blue bar would move to the latest received target. You may fix on the same target, please refer to P.45 “Target Monitor” for related settings.



**Block 4:** This area shows the dynamics, static information of the target ship, and satellite positioning status (**CYPHO-101G only**).(refer to **Picture 5-5-20-1, 5-5-20-2, and 5-5-20-3**). The information here changes automatically and reflects the latest received target information. Please refer to **P. 49 “Target Monitor”** if you need to fix on the specific target.

DYNAMICS		STATIC	
MMSI	416915009		
Nav. Status	Under way using engine		
ROT	0.0°	Heading	0.0°
SOG	0.00Kn	COG	347.9°
Longitude	121°45.789E	Latitude	25°09.158N
Range	0.78 nm	Bearing	N/A
CPA	N/A	TCPA	N/A
Pos. Accu.	Lo		
Receive Time	2008/01/24 14:00:41		

**Picture 5-5-20-1 Dynamics Data**

#### **DYNAMIC DATA**

- **MMSI:** Maritime Mobile Service Identity of the target ship.
- **Nav. Status:** Navigational status of the target ship.
- **ROT:** Rate of turn.
- **Heading:** The direction of the target ship’s stem.
- **SOG:** Speed Over Ground of the selected target.
- **COG:** Course Over Ground of the selected target.
- **Longitude:** Current Longitude of target ship.
- **Latitude:** Current Latitude of target ship.
- **Range:** Range between the selected target and own ship.
- **Bearing:** The related position between own ship and target ship. Using degree(°) to represent.
- **CPA:** Distance of Closest Point of Approach between own ship and target ship.
- **TCPA:** Time to Closest Point of Approach between own ship and target ship.
- **Pos. Accu.:** Position Accuracy; related to the GPS device used.
- **Received Time:** The latest received time of the target ship.

DYNAMICS	STATIC
IMO	0
CALL SIGN	
NAME	
SHIP TYPE	(70)Cargo ship
CARGO	(70)N/A; Harmless
DESTINATION	TAICHUNG
ETA	11/2 01:01
EPFS TYPE	GLONASS
DRAUGHT	9.3m
DIMENSION	A:142m,B:30m,C:8m,D:19m
LENGTH	172m
BEAM	27m
Receive Time	2008/01/24 14:00:41

Picture 5-5-20-2 Static Data

## STATIC DATA

- **IMO:** International Marine Organization Number
- **CALL SIGN:** The call sign of the target ship.
- **NAME:** The name of the target ship.
- **SHIP TYPE:** The type of the target ship.
- **CARGO:** Cargo information of the selected target ship.
- **DESTINATION:** The destination of the selected target ship.
- **ETA:** Estimate Time of Arrival.
- **EPFS TYPE:** Type of Electronic position Fixing device.
- **DRAUGHT:** The draught of the target ship.
- **DIMENSION:** The dimension of the target ship.
- **LENGTH:** The length of the target ship.
- **BEAM:** The width of the target ship.
- **RECEIVE TIME:** The latest received time of the target ship.

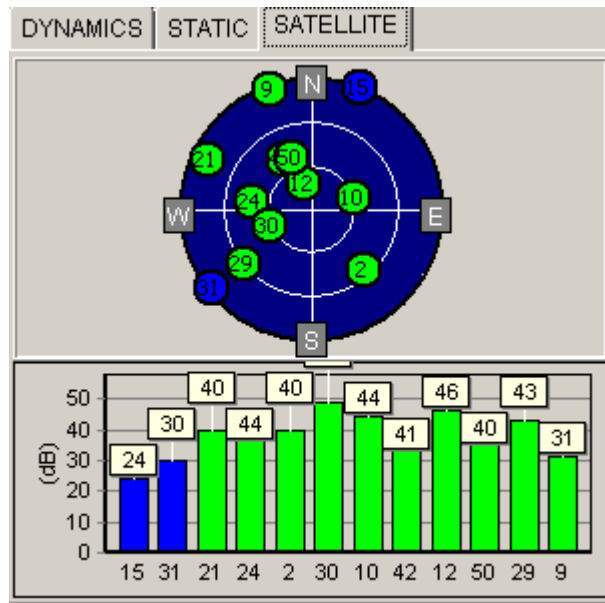

Picture 5-5-20-3 Satellite Positioning Status

### Satellite Positioning Status

- The green spots and bars are the displays of GPS status with individual satellite position and signal strength of the satellites those are in use.
- The blue spots and bars represent the GPS status with position and signal strength of the satellites those are not in use.



## 6. TROUBLE SHOOTING

### 6.1. PROBLEM ANALYSIS (BY STATUS INDICATION LIGHT)

- The color of the status indication light will change in different status. User is able to make a general analysis base on the status described below,

STATUS INDICATION LIGHTS			
Color	Status	Indications	Descriptions
Green	ON	Normal	N/A
	Flash	With wrong input	Please check the power input (9-30 VDC)

- If the problem persists, please follow the below step and restart the unit.
  1. **Disconnect the power cord off the unit, reconnect after 1~2 minutes.**
  2. **Please Refer to section 4.2. to turn on the unit.**
- If the problem still persists, contact your local agent/dealer.

## 6.2. PROBLEM ANALYSIS (HARDWARE)

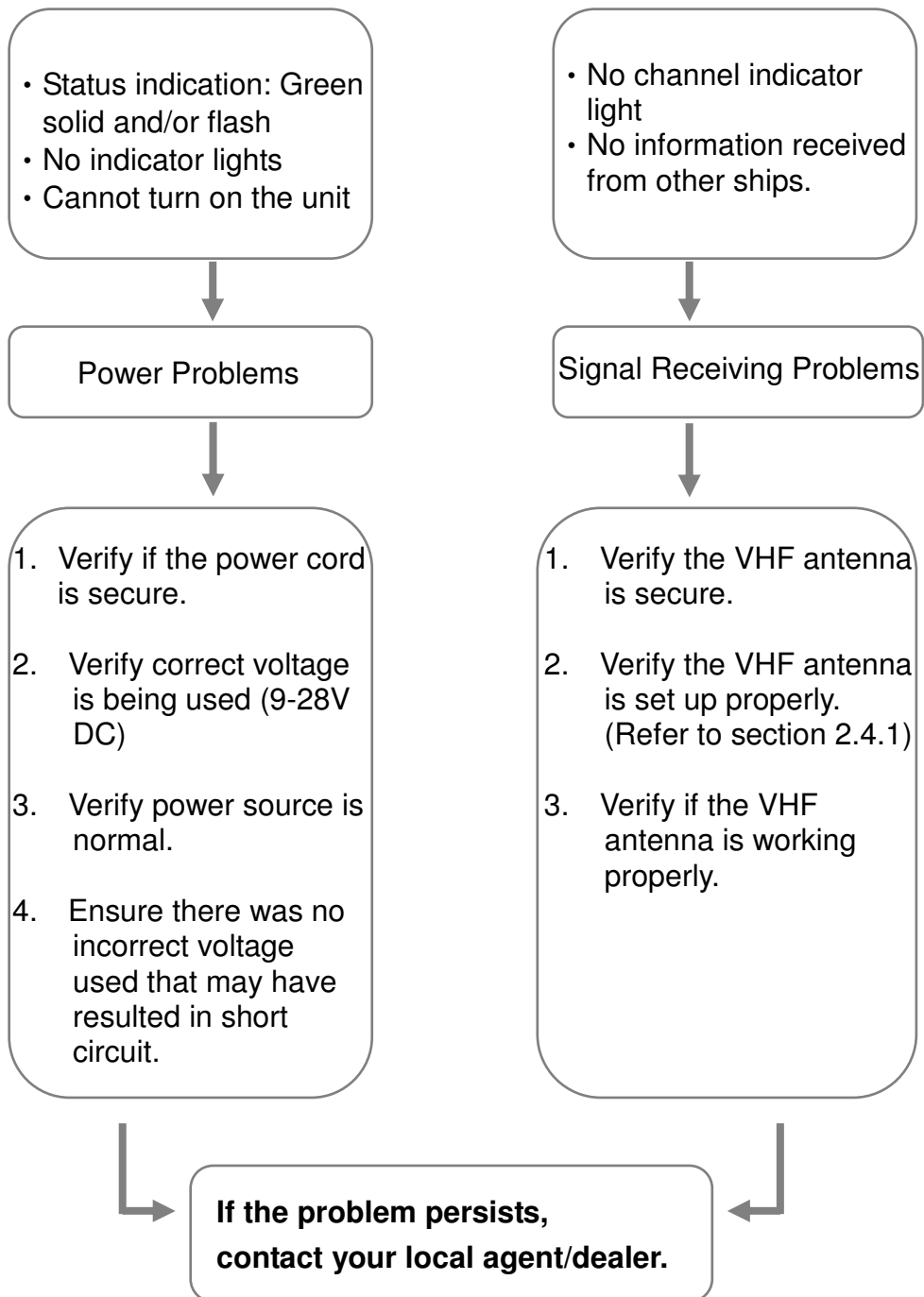



## 7. SPECIFICATIONS

### STANDARDS

---

IEC 60945

### VHF CHANNELS

---

Number of AIS Receivers	Dual-channel parallel receiver
CH-1	Default CH 87B (161.975MHz)
CH-2	Default CH 88B (162.025MHz)
Channel Bandwidth	25KHz

### VHF RECEIVER

---

Message Format	AIS Class A & B messages
Data Rate	9600bps / per channel
Max. Usable Sensitivity	-114 dBm

### GPS RECEIVER

---

Receiving Channels	12 channels
Acquisition Sensitivity	-140dBm
Tracking Sensitivity	-150dBm
Position Accuracy	CEP(50%) 2.5m without SA
Output Rate	1Hz

### POWER SUPPLY

---

Supply Voltage	24V DC (9~30V DC)
Power Consumption	Less than 3W



### LED DISPLAY

---

1. One Power On Indicator
2. Two RX Receiving Indicators

### INTERFACES

---

NMEA0183

RS-232

USB

VHF Antenna Connector      Female Type M(Type N Optional)

GPS Antenna Connector      Female TNC

### ENVIRONMENT

---

Operating Temperature	-15°C~55°C
Storage Temperature	-25°C~70°C
Humidity Operation	0~95%RH at 40°C
Vibration	IEC 60945
Waterproof	IPX5

### PHYSICAL

---

Size in mm (w)	103 mm (140 mm with mounting)
Size in mm (h)	50mm
Size in mm (d)	150mm
Weight	< 1kg



## 8. AMEC World Wide Warranty

### Limited warranty

Subject to the terms, conditions and limitations set forth in this Worldwide Limited Warranty (hereinafter the “Warranty”), AMEC warrants that its products, when properly installed and used, will be free from defects in material and workmanship for a period of twelve (12) months, from the date of first purchase (the ‘Warranty Period’)

For the purposes of this warranty, ‘date of first purchase’ means the date that the product was purchased by the first retail customer, or by the institutional customer, or in the case of a product installed on a new vessel or any other marine related platform by a certified AMEC original equipment manufacturer (a ‘AMEC OEM’), the date that such vessel was purchased by the first retail customer.

AMEC will, at its sole option, repair or replace any defective products or components returned during the Warranty Period in accordance with the terms, conditions and limitations set forth below. **Such repairs or replacement will be the sole remedy of the customer under this Warranty.**

### Standard Warranty Service

To qualify for standard warranty service the product must be returned to a AMEC-certified service agent (i) within the Warranty Period, and (ii) within thirty (30) days of the alleged product failure. Any products returned must be securely packaged and sent pre-paid and insured to AMEC or to a AMEC-certified service agent. All products returned must be accompanied by a copy of the original sales receipt to be eligible for standard warranty service.

### Obtaining Warranty Service

A list of AMEC-certified service agents is available from AMEC Technical Support at [www.alltekmarine.com](http://www.alltekmarine.com)

Other conditions

This Warranty is fully transferable provided that you furnish the original proof of purchase to the AMEC -certified service agent. This Warranty is void if the label bearing the serial number has been removed or defaced.



## Limitation and Exclusions

In addition to any other limitations and exclusions set forth herein, AMEC is not responsible for, and this Warranty does not cover:

- Failure due to abuse, misuse, accident, unauthorized alteration, modification or repair, improper installation or operation (whether or not by a AMEC-certified service agent) or improper storage, shipping damage or corrosion;
- Costs associated with routine system checkouts, alignment/calibration, sea trials or commissioning;
- Defects or damage that result from the use of non-AMEC branded or certified products, accessories or other peripheral equipment, including without limitation housings, parts, or software;
- Aftermarket software (i.e. all software other than the original operating software sold with the products);
- Products that have been refurbished, reconditioned, or remanufactured (The foregoing does not apply to products repaired or replaced pursuant to the terms of this Warranty).
- Products that have been dismantled resulting in the broken label on the Products;
- Costs associated with overtime or premium labor costs;
- Differences in material, coloring or size that may exist between actual products and the pictures or descriptions of such products in our advertising, advertising literature or on the Internet;

**TO THE EXTENT PERMITTED BY APPLICABLE LAW, THE FOREGOING WARRANTY IS AMEC'S SOLE WARRANTY AND IS APPLICABLE ONLY TO NEW PRODUCTS PURCHASED WORLDWIDE. THE PROVISIONS OF THIS WARRANTY ARE IN LIEU OF ANY OTHER WRITTEN WARRANTY, WHETHER EXPRESSED OR IMPLIED, WRITTEN OR ORAL, INCLUDING ANY WARRANTY OF MERCHANTABILITY OR FITNESS FOR A PARTICULAR PURPOSE.**



THE LIABILITY OF AMEC TO A CUSTOMER UNDER THIS WARRANTY, WHETHER FOR BREACH OF CONTRACT, TORT, BREACH OF STATUTORY DUTY OR OTHERWISE SHALL IN NO EVENT EXCEED AN AMOUNT EQUAL TO THE TOTAL PURCHASE PRICE OF THE PRODUCT GIVING RISE TO SUCH LIABILITY AND IN NO EVENT SHALL AMEC BE LIABLE FOR SPECIAL, INCIDENTAL, CONSEQUENTIAL OR INDIRECT DAMAGES OR LOSS OF GOODWILL, REPUTATION, LOSS OF OPPORTUNITY OR INFORMATION, DATA, SOFTWARE OR APPLICATIONS.

SOME JURISDICTIONS DO NOT ALLOW EXCLUSION OR LIMITATION OF INCIDENTAL OR CONSEQUENTIAL DAMAGES SO THE ABOVE LIMITATIONS OR EXCLUSIONS MAY NOT APPLY TO YOU. THIS WARRANTY GIVES YOU SPECIFIC LEGAL RIGHTS AND YOU MAY ALSO HAVE OTHER RIGHTS, WHICH VARY FROM JURISDICTION TO JURISDICTION.

This Warranty supersedes and replaces all previous Warranties.

In the event that any term or provision contained in this Warranty is found to be invalid, illegal or unenforceable by a court of competent jurisdiction, then such provision shall be deemed modified to the extent necessary to make such provision enforceable by such court, taking into account the intent of the parties.

No oral or written representations made by AMEC or any seller, reseller or distributor of the products, including employees and agents thereof, shall create any additional warranty obligations, increase the scope, or otherwise modify in any manner the terms of this Warranty.

All AMEC products sold or provided hereunder are merely aids to navigation. It is the responsibility of the user to exercise discretion and proper navigational skill independent of any AMEC product.



## 9. Federal Communication Commission Interference Statement

This equipment has been tested and found to comply with the limits for a Class A digital device, pursuant to Part 15 of FCC Rules. These limits are designed to provide reasonable protection against harmful interference in a residential installation. This equipment generates uses and can radiate radio frequency energy and, if not installed and used in accordance with the instructions, may cause harmful interference to radio communications. However, there is no guarantee that interference will not occur in a particular installation. If this equipment does cause harmful interference to radio or television reception, which can be determined by turning the equipment off and on, the user is encouraged to try to correct the interference by one of the following measures:

- Reorient or relocate the receiving antenna.
- Increase the separation between the equipment and receiver.
- Connect the equipment into an outlet on a circuit different from that to which the receiver is connected.
- Consult the dealer or an experienced radio/TV technician for help.

This device complies with Part 15 of the FCC Rules. Operation is subject to the following two conditions: (1) This device may not cause harmful interference, and (2) this device must accept any interference received, including interference that may cause undesired operation.

## 10. INDUSTRY CANADA NOTICE

This digital apparatus does not exceed the class A limits for radio noise emissions from digital apparatus set out in the Radio Interference Regulations of the Canadian Department of Communications. Le présent appareil numérique n'émet pas de bruits radioélectriques dépassant les limites applicables aux appareils numériques de la class A prescrites dans le Règlement sur le brouillage radioélectrique édicté par le ministère des Communications du Canada.

## 11. Declaration of Conformity

Hereby, Alltek Marine Electronics Corp. (AMEC) declares that this CYPHO-101G/101/101E is in compliance with the essential requirements and other relevant provisions of Directive 1999/5/EC.

## 12. ABBREVIATIONS

AIS	Automatic Identification System
COG	Course Over Ground
CPA	Distance to Closest Point of Approach
CSTDMA	Carrier-sense time division multiple access
DSC	Digital Selective Calling
ECS	Electronic Chart System
ETA	Estimated Time of Arrival
GPS	Global Positioning System
IMO	International Maritime Organization
MMSI	Maritime Mobile Service Identity
SOG	Speed Over Ground
SRM	Safety Related Message
TCPA	Time to Closest Point of Approach
TDMA	Time Division Multiple Access
UTC	Coordinated Universal Time
VHF	Very High Frequency
VTS	Vessel Traffic Service